

**PHYSICS**

Paper 1 Multiple Choice

5054/12

May/June 2019

1 hour

Additional Materials: Multiple Choice Answer Sheet  
Soft clean eraser  
Soft pencil (type B or HB is recommended)

**READ THESE INSTRUCTIONS FIRST**

Write in soft pencil.  
Do not use staples, paper clips, glue or correction fluid.  
Write your name, centre number and candidate number on the Answer Sheet in the spaces provided unless this has been done for you.  
**DO NOT WRITE IN ANY BARCODES.**

There are **forty** questions on this paper. Answer **all** questions. For each question there are four possible answers **A, B, C** and **D**.  
Choose the **one** you consider correct and record your choice in **soft pencil** on the separate Answer Sheet.

**Read the instructions on the Answer Sheet very carefully.**

Each correct answer will score one mark. A mark will not be deducted for a wrong answer.  
Any rough working should be done in this booklet.  
Electronic calculators may be used.

This document consists of **16** printed pages.

1 Which reading is given to one tenth of a millimetre?

A 3.3 cm

B 3.31 cm

C 3.310 cm

D 3.312 cm

$$\frac{1}{10} \text{ mm} = 0.1 \text{ mm} = 0.01 \text{ cm}$$

2dp approach for cm express ✓

2 A woman runs 2.0 km from X to Y in 20 minutes and then rests at Y for 10 minutes. She then takes 10 minutes to run 1.6 km from Y to Z.

displacement = straight distance between starting to end position

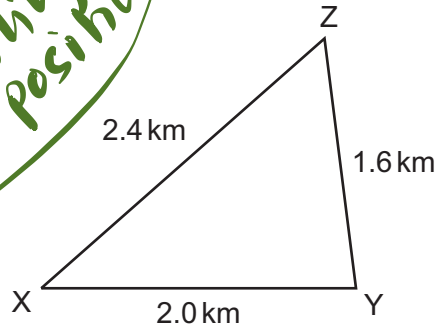

$$\begin{aligned} \text{average velocity} &= \frac{\text{displacement}}{\text{time}} \\ &= \frac{2.4 \text{ km}}{40 \text{ minutes}} \\ &= 0.06 \text{ km/min} \end{aligned}$$

What is the size of her average velocity for the journey from X to Z?

A 0.060 km/minute

B 0.080 km/minute

C 0.090 km/minute

D 0.130 km/minute

Jahangir Masud sir

THE LEGENDS

Jahangir Masud Sir

3 A cyclist travelling in a straight line at 8.0 m/s accelerates to 12 m/s in a time of 6.0 s.

Which expression gives the cyclist's acceleration?

A  $\frac{6}{12-8}$

B  $\frac{8}{12-6}$

C  $\frac{12-6}{8}$

D  $\frac{12-8}{6}$

$$\begin{aligned} a &= \frac{v-u}{t} \\ &= \frac{12-8}{6} \end{aligned}$$

4 The diagram shows the distance–time graph for a moving object.

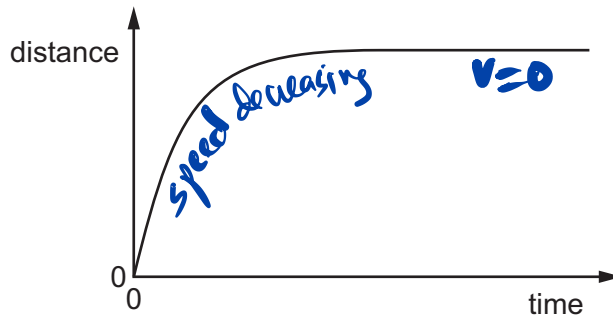

after a certain time distance is not increasing. in other words means stops

What is the moving object?

- A a ball thrown vertically upwards and falling back to the thrower
- B a car, starting from rest, speeding up as it moves away from a traffic signal
- C a rock dropped from a high cliff, falling into the sea below
- D a train braking to a halt as it stops at a station

5 Four of the gravitational forces that act between bodies in the Solar System are listed below.

- P the force on the Moon due to the Earth
- Q the force on the Earth due to the Sun
- R the force on the Earth due to the Moon
- S the force on the Moon due to the Sun

action-reaction pair  
# force must act on two different bodies  
# forces are equal and opposite

Which two forces are a Newton's third law pair (action and reaction)?

- A P and Q
- B P and R
- C Q and S
- D R and S

6 A parachutist of mass 60 kg falls at a steady speed of 10 m/s. The gravitational field strength  $g$  is 10 N/kg.

What is the upward force acting on the parachutist?

- A 0
- B 6.0 N
- C 60 N
- D 600 N

# weight  $W = 60 \times 10 = 600 \text{ N}$   
# upward force = 600 N  
weight = upward force

Resultant force zero

7 A force moves a box up a rough slope.

The diagram shows four forces acting on the box.

Which is the force due to friction on the box?

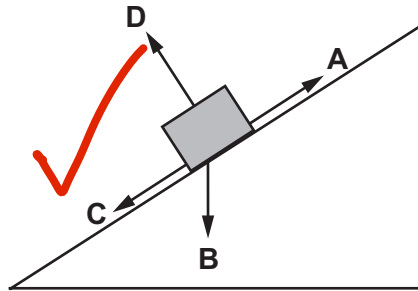

*direction of friction is always opposite to the direction of motion*

8 The mass of object P is greater than the mass of object Q.

The objects contain different amounts of matter and have a different resistance to change of motion.

Which row is correct?

|   | greater amount of matter | greater resistance to change of motion |
|---|--------------------------|--|
| A | P                        | P                                      |
| B | P                        | Q                                      |
| C | Q                        | P                                      |
| D | Q                        | Q                                      |

*more mass → more inertia → more resistance to change of motion*

9 Four objects of different masses are situated in places with different gravitational field strengths.

Which object has the greatest weight?

|   | mass / kg | gravitational field strength<br>N/kg |
|---|-----------|--------------------------------------|
| A | 3.0       | 10.4                                 |
| B | 3.5       | 9.5                                  |
| C | 4.0       | 10.2                                 |
| D | 4.5       | 9.0                                  |

$W = mg$

- $3 \times 10.4$
- $3.5 \times 9.5$
- $4.0 \times 10.2$  ✓
- $4.5 \times 9.0$

10 A uniform metre rule is balanced by a 4.0 N weight as shown.

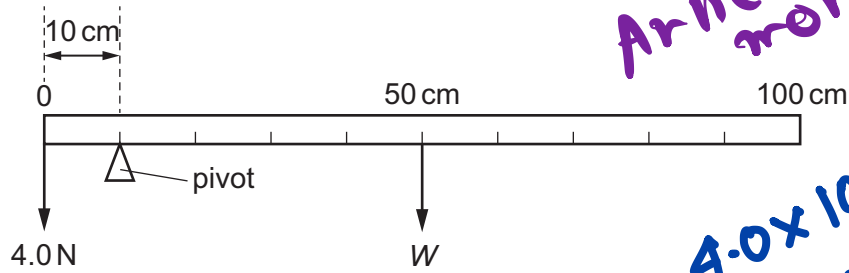

*Anticlockwise moments = clockwise moments*

*$4.0 \times 10 = W \times 40$   
 $W, W = 1.0 \text{ N}$*

What is the weight W of the metre rule?

- A 1.0 N       B 4.0 N       C 16 N       D 40 N

Jahangir Masud sir

11 A large hook sticks into a pencil. The hook and pencil are balanced on the edge of a table, as shown.

Where is the centre of mass of the hook and pencil?

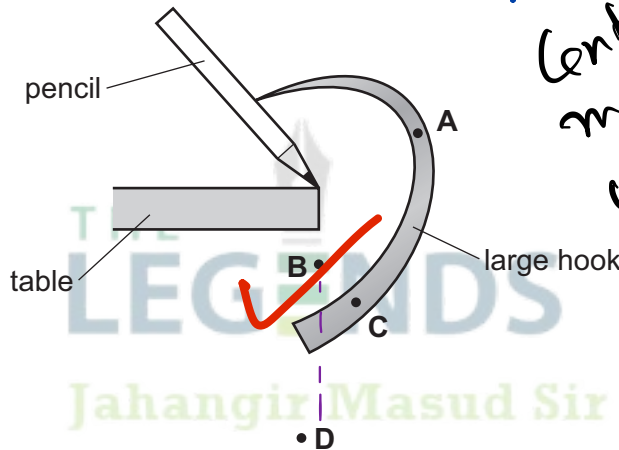

*for equilibrium  
Centre of gravity  
must be in line  
with pivot.  
(above or below  
the pivot)*

12 The diagram shows a graph of load against extension for a material.

At which point is the limit of proportionality?

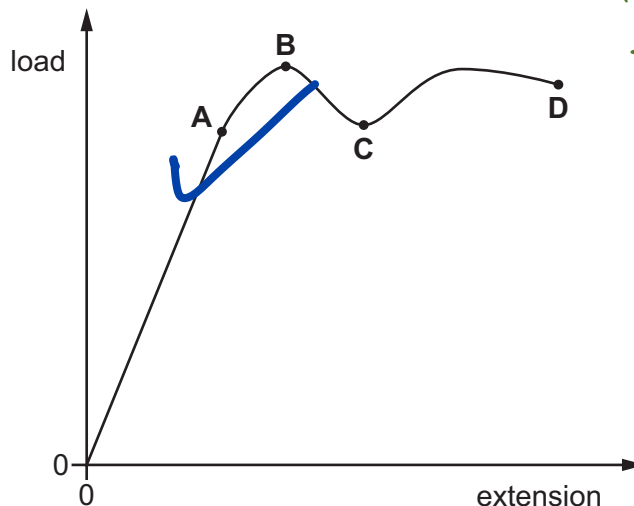

*the point from which  
the line becomes  
curve*

13 A length of metal wire is made from a radioactive isotope of the metal.

The diagram shows masses suspended from the end of the wire.

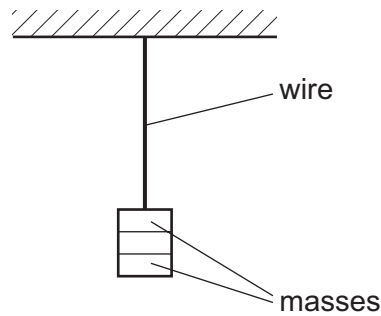

When mass is added, the length of wire is extended. mass removed, it goes to original length.

The masses are removed from the wire.

Which property changes?

- A half-life of the isotope
- B length of the wire
- C mass of the wire
- D melting point of the metal

14 The diagram shows a manometer containing mercury that is sealed at one end.

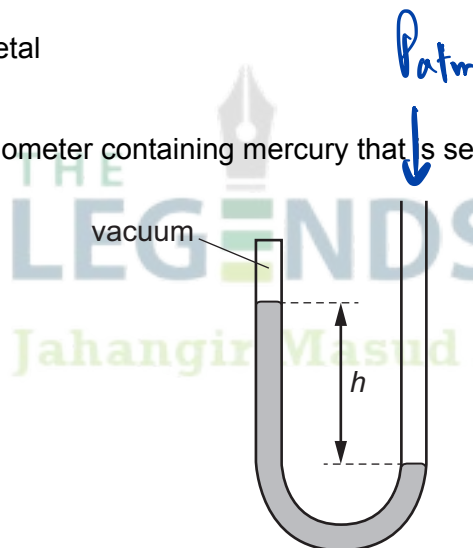

$p_{atm} = \text{atmospheric pressure}$

At higher altitude  $P_{atm}$  is less  
 if  $P_{atm}$  is high  $h$  is high  
 if  $P_{atm}$  is low  $h$  is low

What happens to the distance  $h$  when the manometer is taken higher up a mountain?

- A It decreases, because atmospheric pressure decreases with height.
- B It decreases, because atmospheric pressure increases with height.
- C It increases, because atmospheric pressure decreases with height.
- D It increases, because atmospheric pressure increases with height.

$P \rightarrow \text{double}$   
 $\text{Volume} \rightarrow \text{half}$

15 The pressure on the gas contained in a sealed syringe is slowly doubled. The volume of the gas halves.

What **must** be true about the density and the temperature of the gas?

|   | density          | temperature      |
|---|------------------|------------------|
| A | decreases        | increases        |
| B | increases        | decreases        |
| C | increases        | remains constant |
| D | remains constant | increases        |

Boyle's Law  
↓  
mass  
↓  
temperature

# if  $P$  increases  
but  $V$  constant  
then  $T$  must be  
increased.

16 An object is lifted.

Which expression gives the increase in gravitational potential energy of the object?

- A mass multiplied by its velocity
- B mass multiplied by its acceleration
- C the rate at which work is done
- D weight multiplied by the increase in height

$PE = mgh$   
 $= \text{weight} \times \text{height}$

But if  $P$  increases  
and  $V$  decreases  
by the same  
ratio  
temperature  
remains  
same

17 The diagram shows a small car of mass 500 kg approaching a hill. It moves up the hill with constant speed.

work done =  $mgh$   
work done =  $F \times s$   
→ Fills with  $W = mgh$

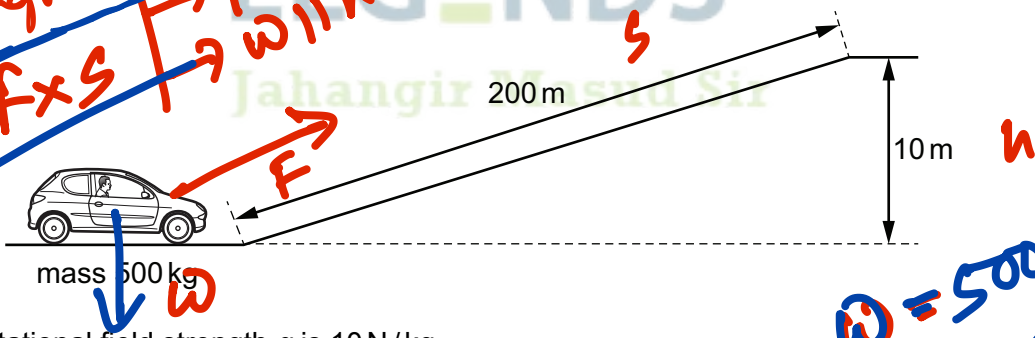

$W = 500 \times 10 \times 10$   
 $= 5.0 \times 10^4 \text{ J}$

The gravitational field strength  $g$  is 10 N/kg.

Ignoring friction, how much work is done in moving the car up the hill?

- A  $5.0 \times 10^3 \text{ J}$
- B  $5.0 \times 10^4 \text{ J}$
- C  $1.0 \times 10^5 \text{ J}$
- D  $1.0 \times 10^6 \text{ J}$

18 Which method of producing electricity does **not** use an a.c. generator?

- A geothermal power station
- B solar panels
- C wave-energy generators
- D wind turbine

All power stations  
uses ac generators

19) Three solar panels have a total area of  $7.2 \text{ m}^2$ . Together, they produce  $1.0 \text{ kW}$  of power.

An area of  $1.0 \text{ m}^2$  of each panel receives  $0.80 \text{ kJ}$  of energy from the Sun in  $1.0 \text{ s}$ .

What is the efficiency of the solar panels?

- A 11%       B 17%      C 52%      D 80%

20 A student suggests three different definitions for power.

- 1 energy transferred per second  
 2 force  $\times$  distance moved  
 3 rate of doing work

Which definitions are correct?

- A 1, 2 and 3      B 1 and 2 only       C 1 and 3 only      D 3 only

21 Which statement is correct?

- A Infrared radiation cannot travel in a vacuum.  
 B Infrared radiation cannot travel in solids or in gases.  
 C Infrared radiation can only travel in a vacuum.  
 D Infrared radiation can travel in a vacuum and in gases.

22 How is *latent heat* defined?

- A the thermal energy absorbed or emitted by unit mass during a change of state without a temperature change  
 B the thermal energy absorbed or emitted by unit mass during unit temperature change  
 C the thermal energy absorbed or emitted during a change of state without a temperature change  
 D the thermal energy absorbed or emitted during unit temperature change

23 In low-pressure hydrogen, there are no forces between the molecules except during collisions with each other.

Which statement describes the motion of a molecule between one collision and the next?

- A It moves with changing speed and continuously changes direction.  
 B It moves with changing speed in a straight line.  
 C It moves with constant speed and continuously changes direction.  
 D It moves with constant speed in a straight line.

# There will be a constant speed and straight line between collisions

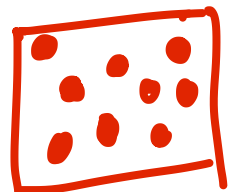

$= 0.80 \text{ kJ/s}$   
 $= 0.80 \text{ kW}$

$\eta = \frac{\text{output}}{\text{input}} \times 100\%$

input power  
 $= 0.80 \times 7.2 \text{ kW}$   
 Output power  
 $= 1.0 \text{ kW}$

$\eta = \frac{1.0}{0.80 \times 7.2} \times 100\%$   
 $= 17\%$

24 A gas is enclosed in a container of fixed volume.  
The gas gains heat energy from an external source.  
What happens to the molecules of the gas?

# temperature increases  
# Kinetic energy increases  
# speed increases

- A They expand.
- B They move faster inside the container.
- C They move further apart.
- D They vibrate with greater frequency.

25 A wave on water travels towards a stationary boat.

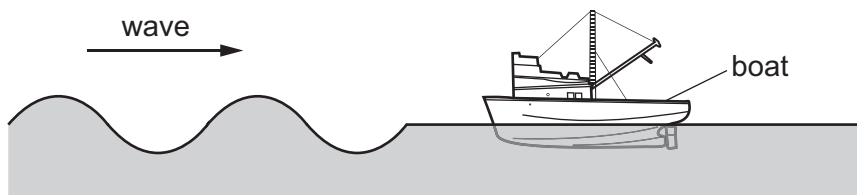

As the wave passes, the boat starts to move up and down and gains kinetic energy from the wave.

Which property of the wave changes as the wave passes the boat?

- A amplitude
- B frequency
- C speed
- D wavelength

Wave loses energy, its amplitude decreases

Energy  $\propto A^2$

$v = f\lambda$

26 Which waves are longitudinal?

- A gamma rays
- B light waves
- C ultrasound waves
- D X-rays

Jahangir Masud sir

27 An object is placed at a distance from a converging lens that is equal to twice the focal length of the lens.

Real and inverted

Which statement about the image is correct?

- A It is enlarged.
- B It is inverted.
- C It is on the same side of the lens as the object.
- D It is virtual.

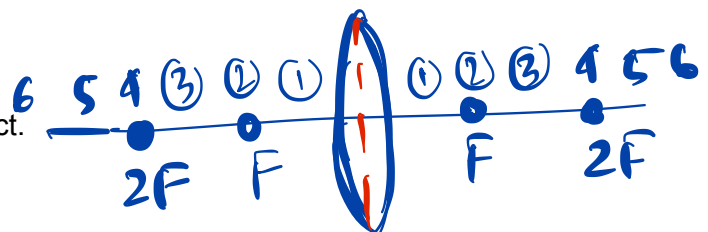

28 The lens in the diagram produces an image  $I$  of the object  $O$ .

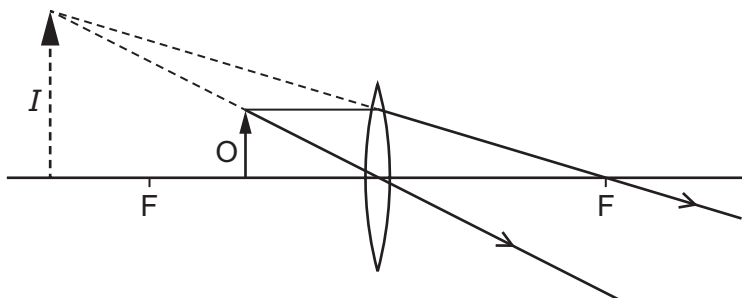

Why is this **not** the ray diagram for a photographic enlarger?

- A The image is magnified.
- B The image is virtual.
- C The lens is a converging lens.
- D The lens is too thin.

formula - 8  
no-1 position

29 What is the approximate range of audible frequencies for a healthy human ear?

- A 2.0 Hz to 2.0 kHz
- B 20 Hz to 2.0 kHz
- C 20 Hz to 20 kHz
- D 200 Hz to 200 kHz

THE LEGENDS

©

30 The speed of sound in air is  $c_a$ , the speed of sound in water is  $c_w$  and the speed of sound in ice is  $c_i$ .

Which relationship is correct?

- A  $c_a > c_i$
- B  $c_a > c_w$
- C  $c_i > c_w$
- D  $c_w = c_a$

solid > liquid > gas

31 One end of each of two bars is marked with an X or a Y, as shown.



bar 1



bar 2

End X of bar 1 is brought close to the N-pole and then to the S-pole of a magnet.

End Y of bar 2 is brought close to the N-pole and then to the S-pole of the magnet.

The table shows what happens.

|                  | end X of bar 1 | end Y of bar 2 |
|------------------|----------------|----------------|
| N-pole of magnet | attracted      | attracted      |
| S-pole of magnet | attracted      | repelled       |

What materials are bar 1 and bar 2 made from?

|   | bar 1  | bar 2  |
|---|--------|--------|
| A | copper | iron   |
| B | iron   | steel  |
| C | steel  | copper |
| D | steel  | iron   |

*magnetic materials*  
*Iron, Cobalt, Nickel*  
*Fe, Co, Ni*

THE LEGENDS  
 Jahangir Masud Sir

32 The diagram shows a car ignition switch and starter motor.

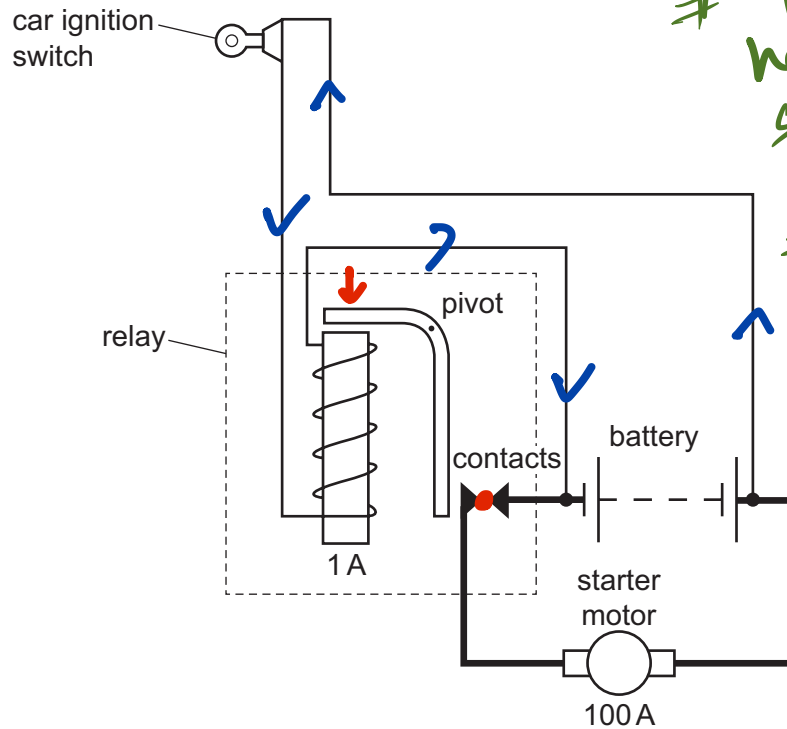

(and long as well)  
 # thinner wire has high resistance so low current  
 # Thicker wire has low resistance so high current (same for short wire)

The ignition switch is in a circuit with long, thin wires. The starter motor is in a circuit with short, thick wires.

What is the explanation for the choice of wires?

- A Each circuit needs to contain the same total mass of wire.
- B Thicker wires heat up more quickly when the relay is switched on.
- C Thin wires have lower resistances.
- D The ignition switch circuit carries a smaller current than the starter motor circuit.

33 The diagram shows a simple circuit.

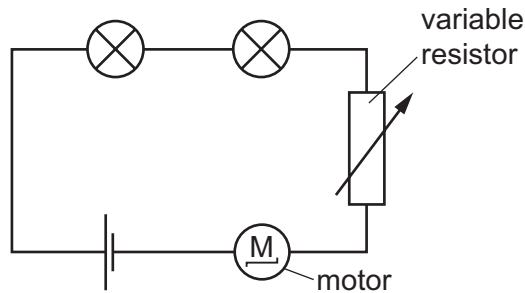

What happens when the resistance of the variable resistor is increased?

- A The lamps are dimmer and the motor rotates more quickly.  
 B The lamps are dimmer and the motor rotates more slowly.  
 C The lamps have the same brightness and the motor rotates more quickly.  
 D The lamps have the same brightness and the motor rotates more slowly.

All are connected in series  
 so, voltage is divided  
 V across motor and lamp decreases.  
 so dimmer

34 The diagram shows a simple electrical circuit.

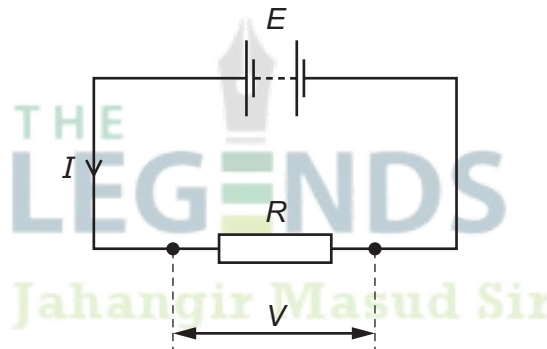

Which statement **cannot** be correct?

- A The current  $I$  is 2 A.  
 B The e.m.f.  $E$  is 12 J.  
 C The p.d.  $V$  (across the resistor) is 10 V.  
 D The resistance  $R$  is  $5\ \Omega$ .

$$V = IR$$

$$10 = 2 \times 5$$

35 The cable to an electric cooker contains a live wire, a neutral wire and an earth wire.

When the cooker is working correctly, in which wires are the currents equal?

- A the live, the neutral and the earth  
 B the live and the earth only  
 C the neutral and the earth only  
 D the neutral and the live only

Always same current flows through live and neutral because this is basically same path

- 36 The manufacturer of an electrical heater states that only one heater must be connected to the mains wiring through any fuse.

The current in the circuit with only one heater is 9 A. The fuse rating is 10 A.

Despite the warning, a second identical heater is added, as shown. When the switch is closed the fuse blows.

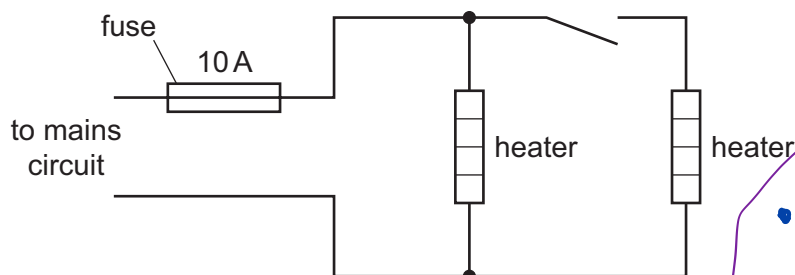

The fuse is replaced with a 20 A fuse.

What happens when the switch is closed?

- A** Each heater only receives half the correct current.  
**B** Each heater receives twice the correct current.  
**C** The circuit wiring connecting the heaters to the mains may overheat.  
**D** The fuse melts when the heaters are switched on.

two heaters jointly will call more current to operate. Due to higher rating fuse it may not melt but the wire will be overheated.

- 37 A coil is rotating in a magnetic field. The coil is connected to an oscilloscope. The diagram shows the trace on the screen of the oscilloscope.

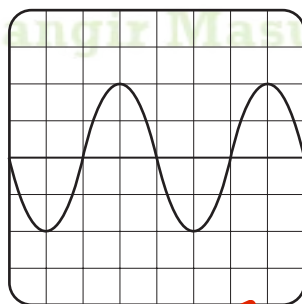

The coil now speeds up and rotates twice as fast.

Which diagram shows the new trace?

**A**

**B**

**C**

**D**

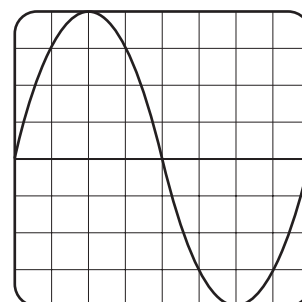
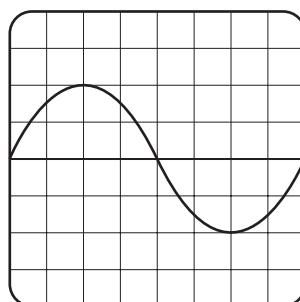
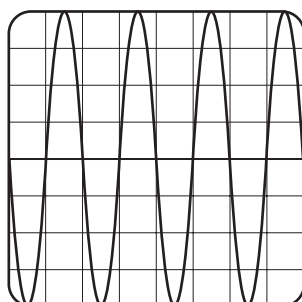
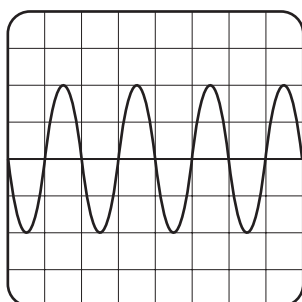

38 A teacher uses the circuit shown.

Huge Voltage drop through long transmission line

$P = VI$

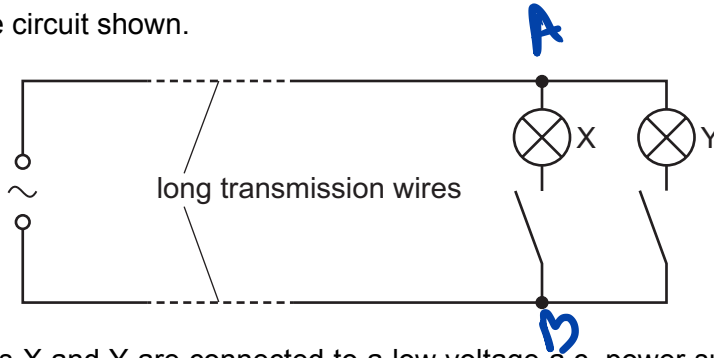

The identical lamps X and Y are connected to a low voltage a.c. power supply by high resistance transmission wires. Both lamps are switched on.

Lamp X is then switched off. Lamp Y stays switched on.

What happens to the voltage and the power supplied to lamp Y?

|   | the voltage supplied to lamp Y | the power supplied to lamp Y |
|---|--------------------------------|------------------------------|
| A | decreases                      | decreases                    |
| B | decreases                      | stays the same               |
| C | increases                      | increases                    |
| D | increases                      | stays the same               |

When X and Y both closed effective R decreases then AB has less V to deliver.

$(V=IR)$

39 A car battery supplies a current in one direction. A current in the opposite direction recharges the battery.

When X open Y has higher R, V across Y increases hence P across Y increases

$(V=IR)$

$P=VI$

Which circuit recharges the battery, using an alternating current (a.c.) supply and a diode?

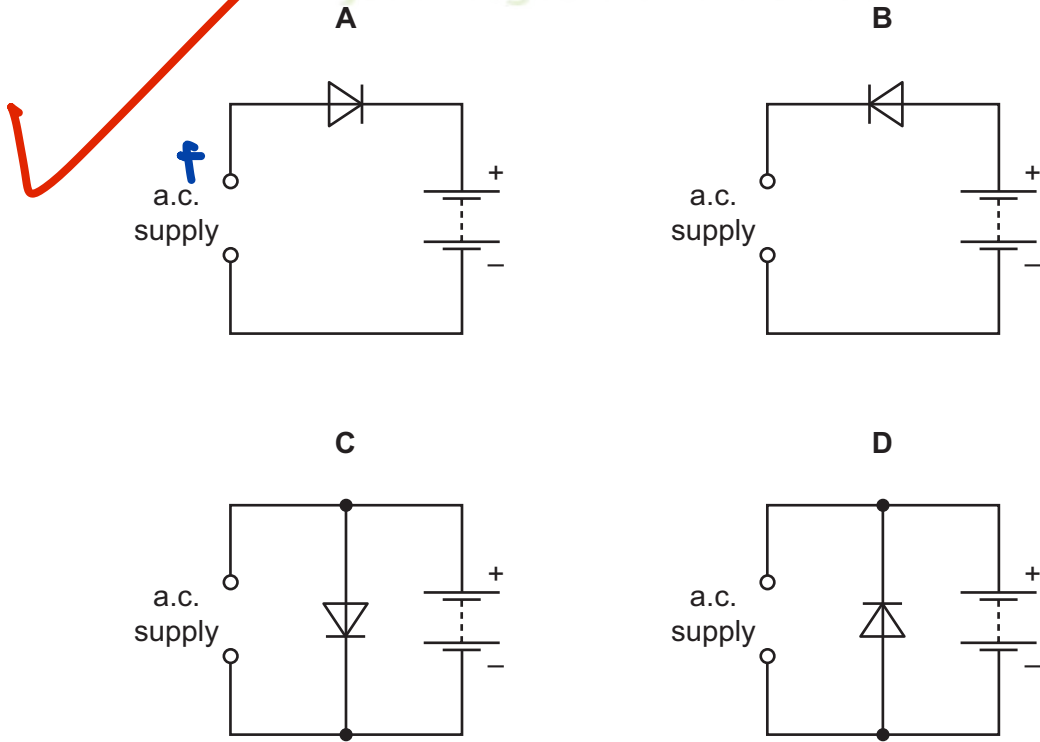

forward bias

reverse bias

40 A proton has charge  $q$  and mass  $m$ .

What is the charge and what is the mass of an alpha-particle?

|   | charge | mass |
|---|--------|------|
| A | $q$    | $2m$ |
| B | $2q$   | $2m$ |
| C | $2q$   | $4m$ |
| D | $4q$   | $2m$ |

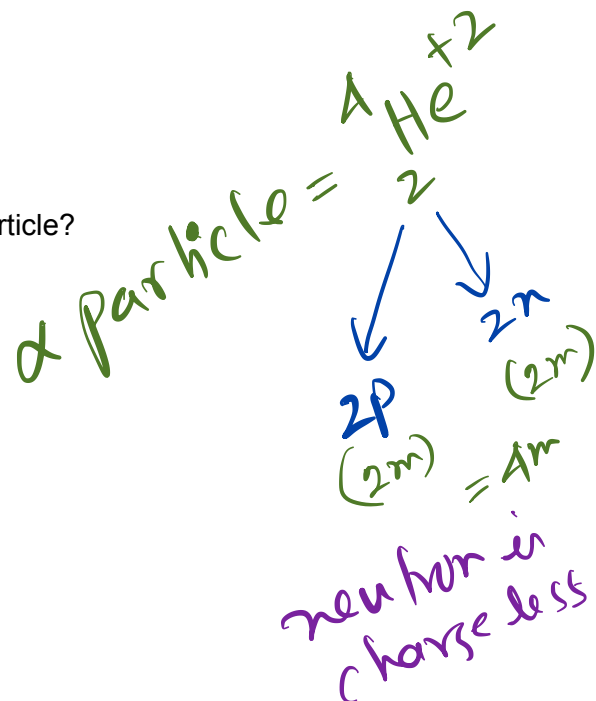

Permission to reproduce items where third-party owned material protected by copyright is included has been sought and cleared where possible. Every reasonable effort has been made by the publisher (UCLES) to trace copyright holders, but if any items requiring clearance have unwittingly been included, the publisher will be pleased to make amends at the earliest possible opportunity.

To avoid the issue of disclosure of answer-related information to candidates, all copyright acknowledgements are reproduced online in the Cambridge Assessment International Education Copyright Acknowledgements Booklet. This is produced for each series of examinations and is freely available to download at [www.cambridgeinternational.org](http://www.cambridgeinternational.org) after the live examination series.

Cambridge Assessment International Education is part of the Cambridge Assessment Group. Cambridge Assessment is the brand name of the University of Cambridge Local Examinations Syndicate (UCLES), which itself is a department of the University of Cambridge.

CANDIDATE  
NAME

|  |
|--|
|  |
|--|

CENTRE  
NUMBER

|  |  |  |  |  |
|--|--|--|--|--|
|  |  |  |  |  |
|--|--|--|--|--|

CANDIDATE  
NUMBER

|  |  |  |  |
|--|--|--|--|
|  |  |  |  |
|--|--|--|--|

**PHYSICS**

Paper 2 Theory

5054/22

May/June 2019

1 hour 45 minutes

Candidates answer on the Question Paper.  
No Additional Materials are required.

**READ THESE INSTRUCTIONS FIRST**

Write your centre number, candidate number and name on all the work you hand in.  
Write in dark blue or black pen.  
You may use an HB pencil for any diagrams or graphs.  
Do not use staples, paper clips, glue or correction fluid.  
**DO NOT WRITE IN ANY BARCODES.**

**Section A**

Answer **all** questions.  
Write your answers in the spaces provided on the Question Paper.

**Section B**

Answer any **two** questions.  
Write your answers in the spaces provided on the Question Paper.

Electronic calculators may be used.  
You may lose marks if you do not show your working or if you do not use appropriate units.

At the end of the examination, fasten all your work securely together.  
The number of marks is given in brackets [ ] at the end of each question or part question.

This document consists of **19** printed pages and **1** blank page.

## Section A

Answer **all** the questions in this section. Answer in the spaces provided.

- 1 A student records the mass and volume of two irregular objects, one made of iron and the other of copper. The student uses the equipment shown in Fig. 1.1.

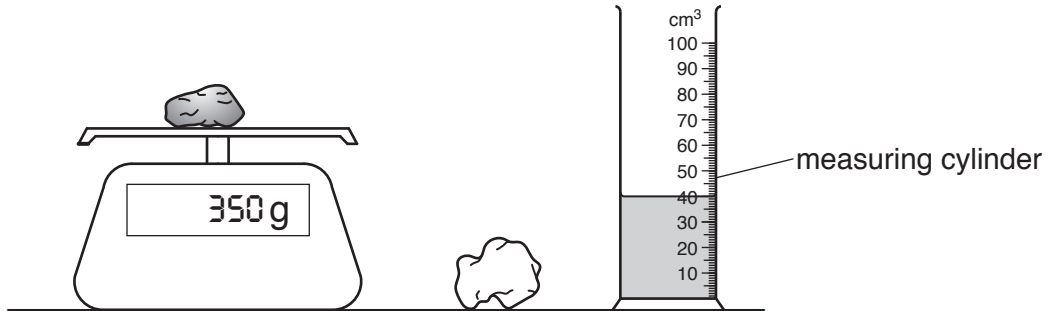

Fig. 1.1

Table 1.1 shows the results obtained.

Table 1.1

|        | mass/g | volume/cm <sup>3</sup> |
|--------|--------|------------------------|
| iron   | 400    | 51                     |
| copper | 350    | 39                     |

- (a) Describe how to determine the volume of an irregular object with the measuring cylinder.

.....

.....

.....

.....

.....

..... [2]

- (b) Calculate the density of iron.

density = ..... [2]

(c) A third object, which is also made of copper, has the same volume as the iron object.

Calculate the mass of this copper object.

mass = ..... [2]

(d) State and explain what happens to the density of the iron object when it is heated.

.....  
.....  
..... [1]

[Total: 7]



- 2 Fig. 2.1 shows a container of gas connected to a manometer. The tube in the manometer has a constant cross-sectional area.

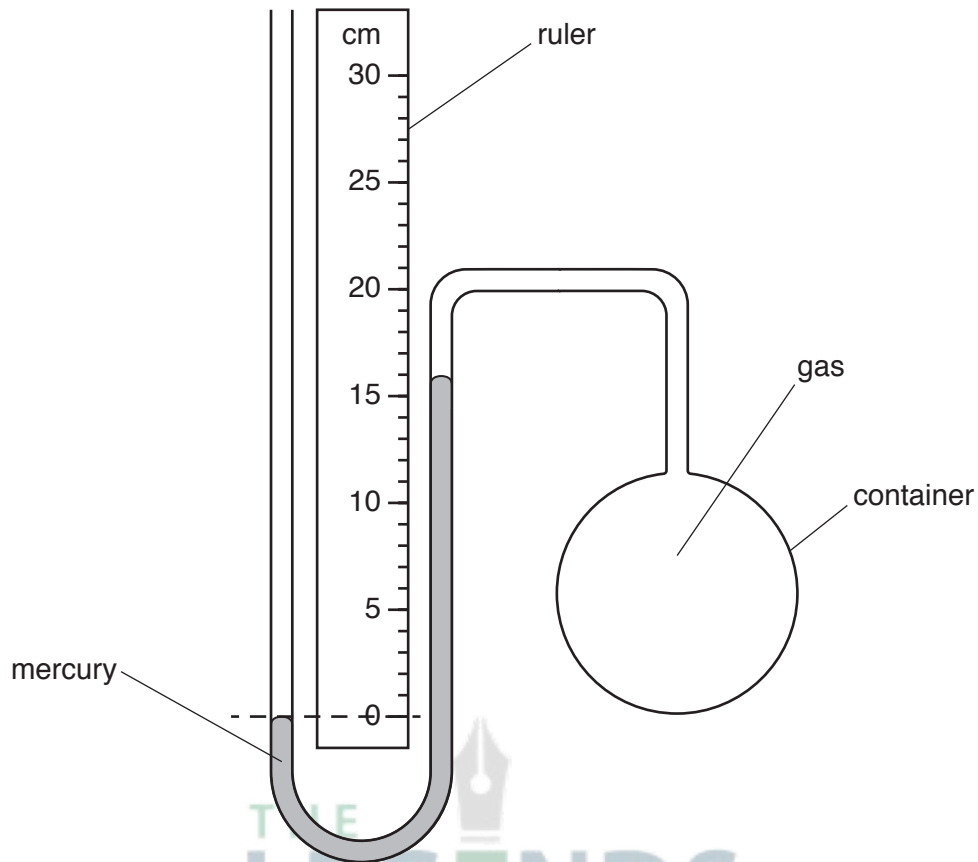

Fig. 2.1

The gas in the container exerts a pressure.

- (a) Define the term *pressure*.

.....  
 ..... [1]

- (b) The density of mercury is  $1.4 \times 10^4 \text{ kg/m}^3$ . The gravitational field strength  $g$  is  $10 \text{ N/kg}$ .

The pressure of the atmosphere is  $1.0 \times 10^5 \text{ Pa}$ .

Calculate the pressure of the gas in the container.

pressure = ..... [3]

- (c) In Fig. 2.1, the mercury level on the left-hand side of the manometer is lower than on the right-hand side.

The gas inside the container is heated. This causes the mercury levels on both sides to become the same.

- (i) Determine the mercury level, as shown on the ruler, when this happens.

..... [1]

- (ii) Explain, in terms of the gas molecules, what causes the level of mercury to become the same.

.....  
.....  
.....  
.....  
.....  
.....  
..... [3]

[Total: 8]



3 Fig. 3.1 shows three rays of light travelling in water from a light source S.

One ray of light is totally internally reflected at the boundary between water and air.

Angle of denser medium for which angle at less denser medium is 90

$$n = \frac{\sin 90^\circ}{\sin c}$$

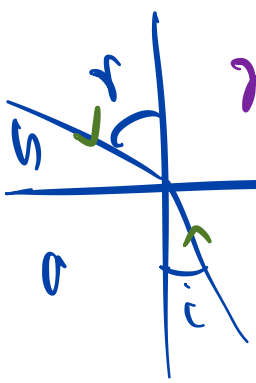

$$n_a = \frac{\sin r}{\sin i}$$

Jahangir Masud sir

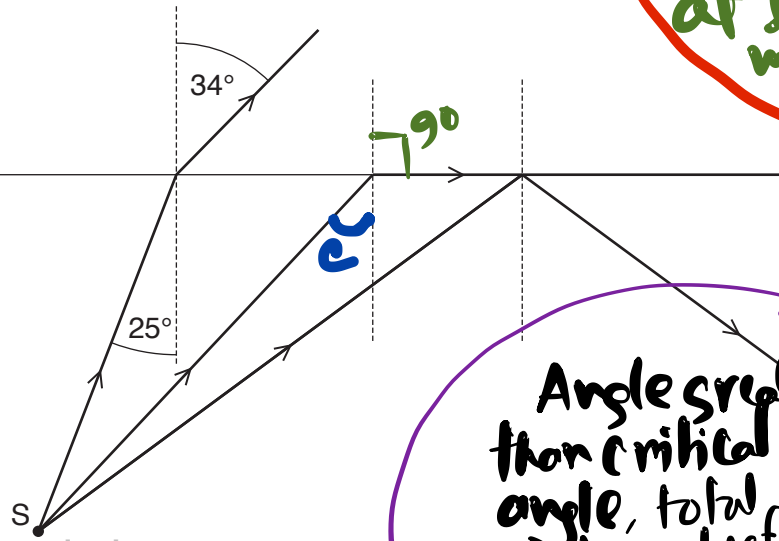

Fig. 3.1 (not to scale)

Angle greater than critical angle, total internal reflection occurs

(a) On Fig. 3.1, mark the critical angle and label it c. [1]

(b) State why only one of the three rays is totally internally reflected.  
 the right most ray has angle greater than critical angle. [1]

(c) Calculate:

(i) the refractive index for water

$$n_{\text{water}} = \frac{\sin 34^\circ}{\sin 25^\circ}$$

refractive index = 1.3 [2]

(ii) the critical angle for the boundary between water and air.

$$n = \frac{1}{\sin c} \quad n, \sin c = \frac{1}{n} = \frac{1}{1.3}$$

$$c = \sin^{-1}\left(\frac{1}{1.3}\right) = 50.2^\circ$$

critical angle = [2]

Technique  
 # find the refractive index of denser medium using  $\frac{\sin i}{\sin r}$   
 # Use formula  $n = \frac{1}{\sin c}$

[Total: 6]

- 4 A star emits electromagnetic radiation over a range of wavelengths.

Fig. 4.1 shows the brightness of the radiation from the star at different wavelengths.

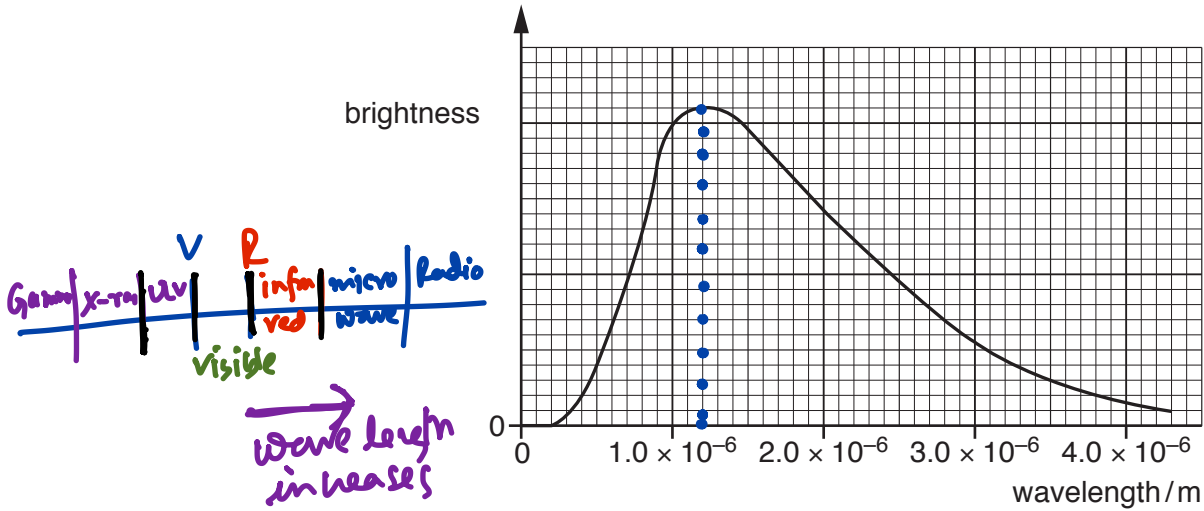

Fig. 4.1

Radiation from the star is brightest at one wavelength.

- (a) Determine the wavelength where the radiation is brightest.

wavelength =  $1.2 \times 10^{-6}$  m ..... [1]

- (b) Visible light has a wavelength between  $4.0 \times 10^{-7}$  m and  $7.0 \times 10^{-7}$  m.

The radiation in (a) lies just outside the visible part of the electromagnetic spectrum.

State the name of the region of the spectrum that contains the radiation in (a).

Infrared ..... [1]

- (c) Determine the frequency of the radiation in (a).

The speed of light is  $3.0 \times 10^8$  m/s.

$$f = \frac{v}{\lambda} = \frac{3.0 \times 10^8}{1.2 \times 10^{-6}} = 2.5 \times 10^{14} \text{ Hz}$$

frequency =  $2.5 \times 10^{14}$  Hz ..... [3]

[Total: 5]

5 (a) Fig. 5.1 shows part of a machine used to investigate electrostatic charging.

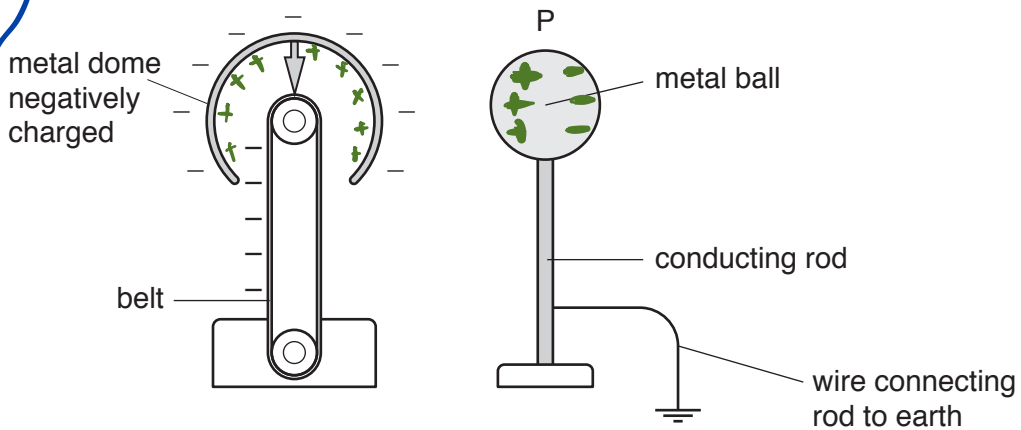

Fig. 5.1

Before the machine is switched on the metal dome and the ball are uncharged.

When the machine is switched on, the metal dome becomes negatively charged.

Explain how charging the dome causes the metal ball P to become positively charged.

Negative charge at metal dome repel the negative charge on metal ball. So the electrons will move to the ground and positive charges will remain at metal ball.

[2]

Jahangir Masud Sir

- (b) A photocopier works using electrostatic charging. It contains a drum whose surface conducts charge where it is exposed to light.

Fig. 5.2 shows a piece of paper, the drum and the heater of a photocopier.

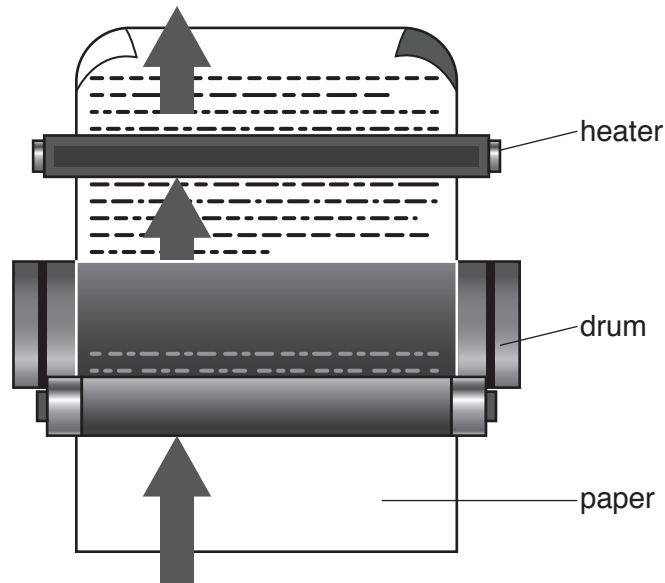

Fig. 5.2

The photocopier produces a copy of an original page on a piece of paper.

The sentences below describe the process of making the copy but the sentences are in the wrong order.

- A** The drum is given a positive charge.
- B** The positively charged parts of the drum attract a black powder. (3)
- C** Where light hits the drum, the positive charge leaks away. (2)
- D** An image of the original page is projected onto the drum. (1)
- E** The drum rolls against a piece of paper, transferring powder to the paper. (4)
- F** The paper is heated which makes the black powder stick to it.

Arrange the sentences in the correct order. The first and last sentences are already in the correct boxes.



[Total: 4]

- 6 Two lamps, P and Q, are connected to a battery of electromotive force (e.m.f.) 6.0V and an ammeter, as shown in Fig. 6.1.

Electric Circuit

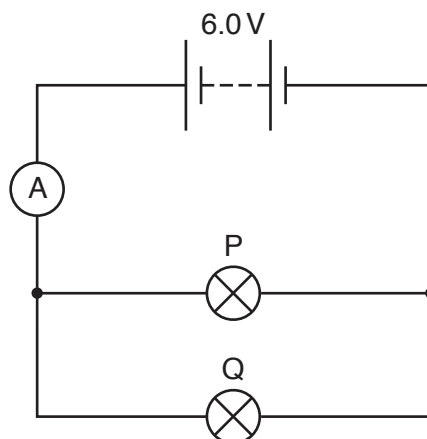

$$A = 0.65 \text{ A}$$

Fig. 6.1

Jahangir Masud sir

Lamp P has a resistance of  $15 \Omega$ . The ammeter reading is 0.65A.

- (a) Calculate the current in lamp P.

$$I = \frac{V}{R} = \frac{6.0}{15} = 0.40 \text{ A}$$

current = 0.40A [2]

- (b) Calculate the resistance of lamp Q.

$$R = \frac{V}{I} \quad I_Q = (0.65 - 0.40) \text{ A} = 0.25 \text{ A}$$

$$= \frac{6.0}{0.25} = 24 \Omega$$

resistance = 24  $\Omega$  [2]

- (c) The two lamps are now connected in series to the ammeter and the same battery.

- (i) In the space below draw the circuit diagram.

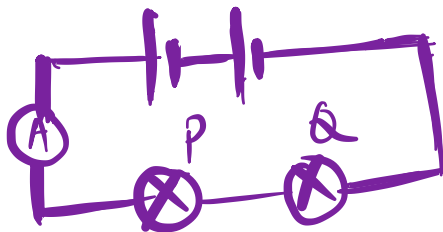

[1]

- (ii) Explain why the ammeter reading is less than 0.65A when the lamps are connected in series.

total resistance increases so current decreases.

[1]

[Total: 6]

7 Fig. 7.1 shows a copper wire placed on two copper rods in the magnetic field between the poles of a magnet.

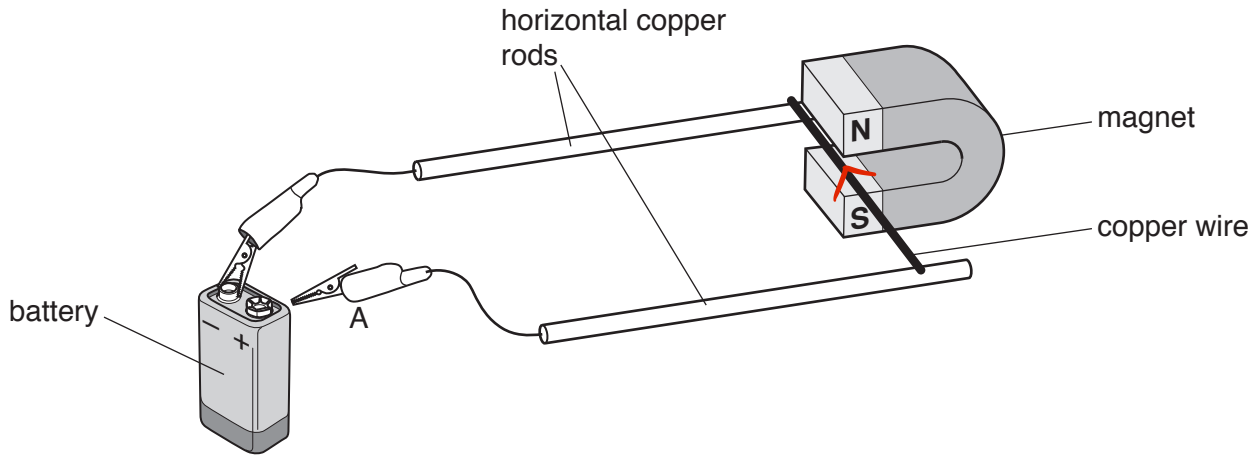

Fig. 7.1

The crocodile clip A touches the positive terminal of the battery. This causes the copper wire to move.

(a) On Fig. 7.1, mark with an arrow the direction of the current in the copper wire. [1]

(b) Explain why the copper wire moves along the copper rods.

Current passes through copper wire produces magnetic field. This magnetic field interacts with the magnetic field of the fixed magnet that produces the force on the copper wire. [2]

(c) Name two different devices that use this effect.

1. Electric motor
2. Loud speakers

[Total: 5]

Motor → force/motion  
 Generator → electricity

8 Fig. 8.1 shows a device that is used to show the force on an electron in an electric field.

DC

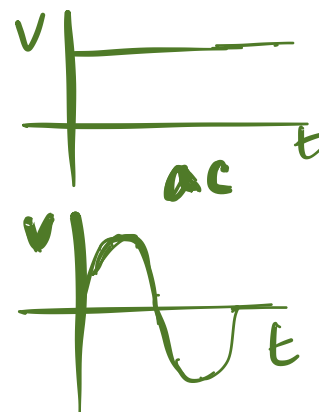
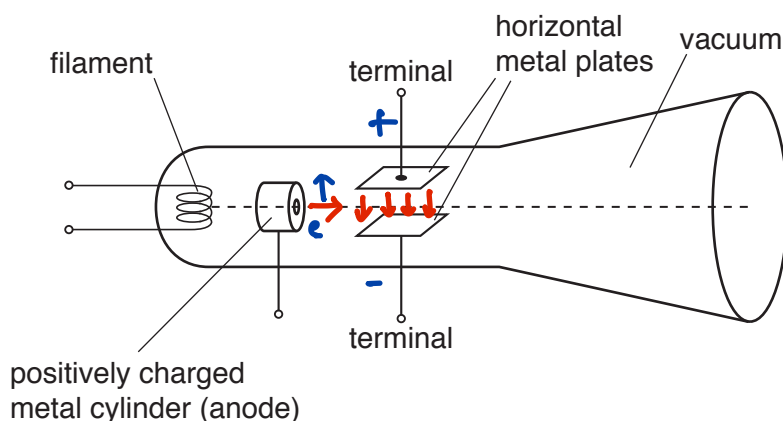
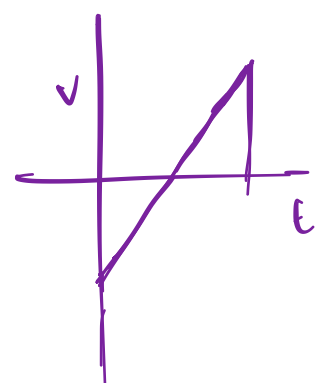

Fig. 8.1

- (a) Explain how a continuous flow of electrons from the filament is produced in this apparatus.

filament is heated so electrons are emitted due to thermionic emission. These electrons are getting attracted by anode.

[2]

- (b) When an electron is in an electric field there is a force on the electron.

The direction of this force is in the opposite direction to the electric field.

Describe how the metal plates in Fig. 8.1 can be used to show this.

The terminal will be connected between with power supply which has positive and negative. The electrons will be deflected towards positive end.

[2]

[Total: 4]

Section B

Answer **two** questions from this section. Answer in the spaces provided.

- 9 Fig. 9.1 shows a map of the route taken by a car as it travels from town A to town B.

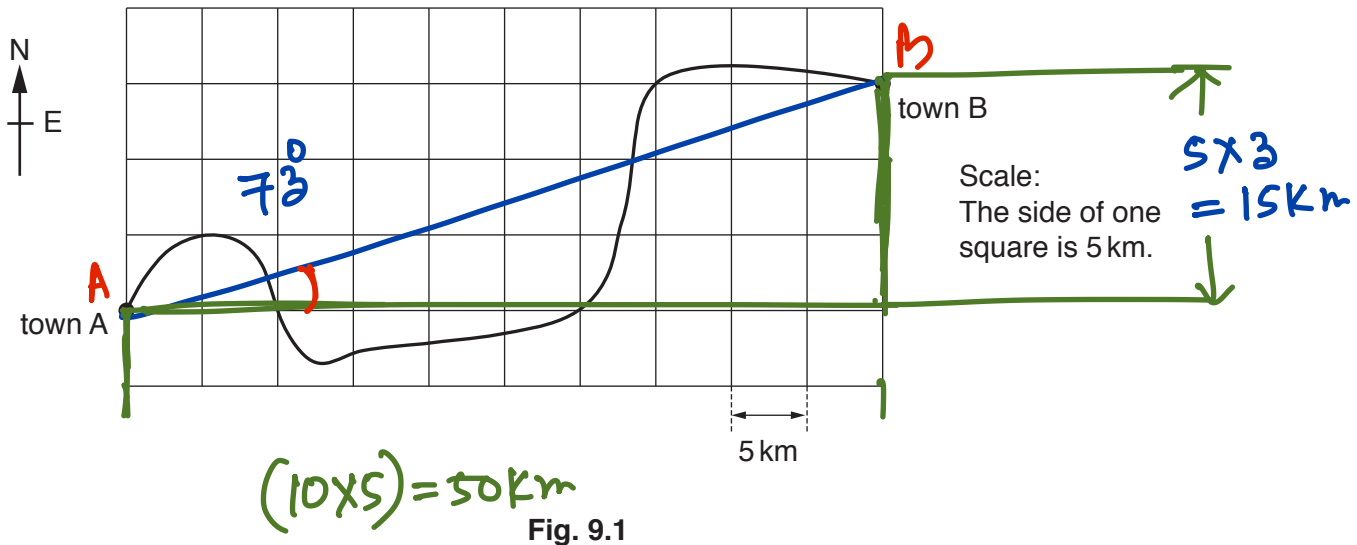

The journey involves a distance and a displacement.

- (a) (i) Using the scale on Fig. 9.1, determine the displacement in travelling from A to B.

$$AB^2 = 50^2 + 15^2$$

$$\therefore AB = \sqrt{50^2 + 15^2} = 52.2 \text{ km}$$

size of displacement = 52.2 km

direction of displacement = 73° E of N

[3]

- (ii) State how *distance* differs from *displacement*.

.....  
 .....  
 ..... [1]

- (iii) In some parts of the journey, the car is travelling at a constant speed but is also accelerating.

Explain how this is possible.

.....  
 .....  
 ..... [2]

(b) At town B the car makes an emergency stop.

The total stopping distance of the car is the thinking distance added to the braking distance.

(i) Describe what is meant by the *thinking distance*.

.....  
..... [1]

(ii) The brakes on the car work badly. This increases the braking distance.

State **two** other factors that increase the braking distance.

1. ....  
.....  
2. ....  
..... [2]

(c) The mass of the car and driver is 1200 kg. Just before the brakes are applied, the speed of the car is 30 m/s.

(i) Calculate the kinetic energy of the car and driver just before the brakes are applied.

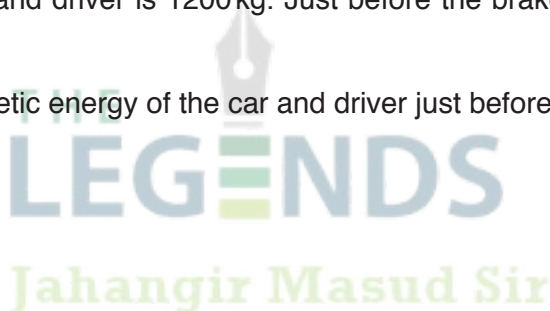

kinetic energy = ..... [3]

(ii) The braking force that stops the car is 1800 N.

Calculate the deceleration of the car.

deceleration = ..... [2]

(iii) Explain why the temperature of the brakes increases during braking.

.....  
..... [1]

[Total: 15]

- 10 Fig. 10.1 is a diagram of a soldering iron. Solder is a mixture of metals used to make a permanent contact between electrical wires.

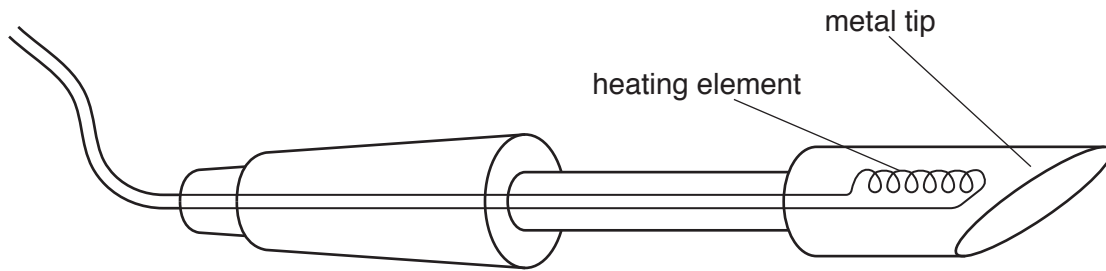

Fig. 10.1

The heating element raises the temperature of the metal tip. When solder is placed against the tip, the solder melts over the wires to be joined. When the solder cools, it solidifies and the permanent connection is made.

The working temperature of the metal tip is  $380^{\circ}\text{C}$ .

- (a) The boxes in Fig. 10.2 show two materials and some different melting points.

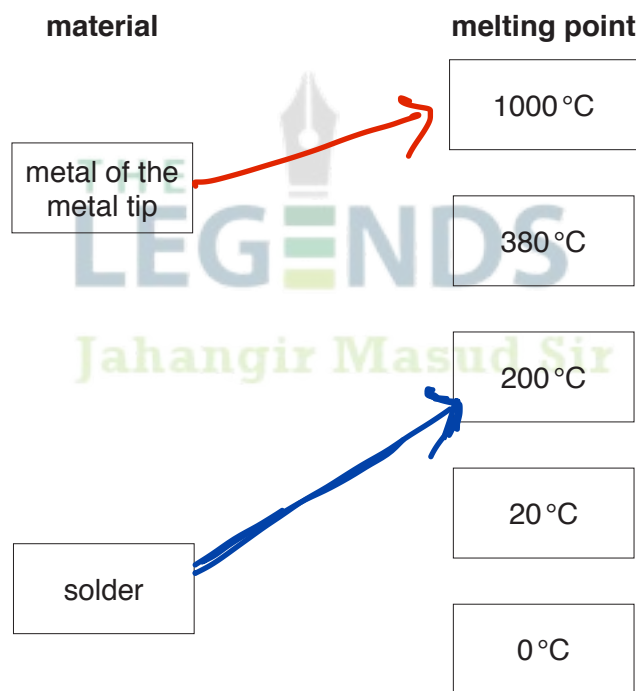

Fig. 10.2

On Fig. 10.2, draw a line from the metal of the metal tip and a line from the solder to a suitable melting point for each. [2]

- (b) The heating element is rated at 24 V, 3.3 A.

The heating element is switched on.

The temperature of the metal tip rises from 20 °C to 320 °C in the first 10 s.

- (i) Calculate the electrical energy supplied to the heating element in the first 10 s.

$$E = VIt$$

$$= 24 \times 3.3 \times 10$$

$$= 790 \text{ J}$$

energy = 790 J ..... [2]

- (ii) The metal tip is made of copper and has a mass of 2.3 g. The specific heat capacity of copper is 0.39 J/(g °C).

Calculate the thermal energy (heat) gained by the metal tip in the first 10 s.

$$Q = mc\Delta\theta$$

$$= 0.23 \times 0.39 \times (320 - 20)$$

$$= 270 \text{ J}$$

thermal energy = 270 J ..... [3]

- (c) (i) Describe, in terms of free electrons, the process by which heat transfers through the metal tip.

Electrons get thermal energy from hotter part and move to other part of conductor and hit on molecules.

Jahangir Masud Sir

..... [2]

- (ii) Heat is lost from the metal tip by convection in the air.

Explain how convection occurs in the air.

..... [2]

(d) The temperature of the metal tip is measured with a thermocouple.

- (i) In the space below, draw a labelled diagram of a thermocouple. Mark with a letter H the part of the thermocouple that is placed on the metal tip.

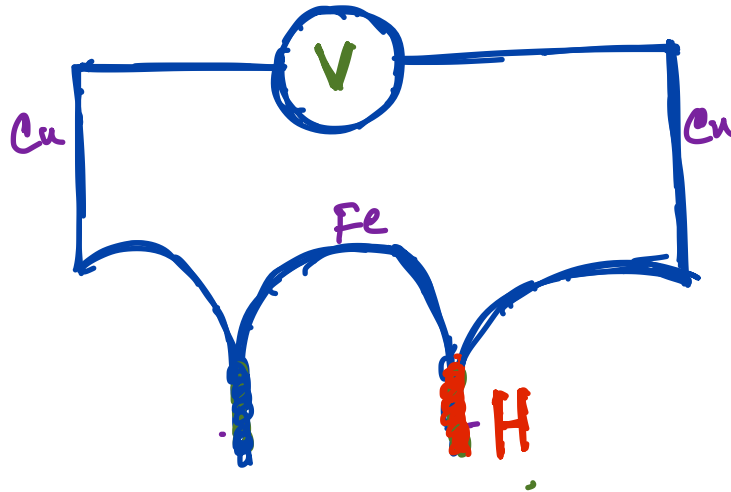

[2]

- (ii) State **two** reasons why a thermocouple thermometer is suitable for measuring how the temperature of the metal tip varies during the first 10s.

1. Can measure the rapid temperature change.
2. Can measure high temperature.

[2]

[Total: 15]

11 (a) Stars are formed inside a cloud of gas and dust in space.

When a star forms, the cloud first becomes smaller as it collapses.

(i) State what causes the gas cloud to collapse.

..... [1]

(ii) Eventually nuclear fusion occurs in the star.

State **two** conditions required for nuclear fusion to occur in the star.

1. ....

2. ....

[2]

(b) When a large star explodes, nuclei of heavy elements are formed.

One such nucleus is uranium-235 ( ${}^{235}_{92}\text{U}$ ).

(i) State the name and the number of each type of particle found in one nucleus of  ${}^{235}_{92}\text{U}$ .

name of particle ..... number found in nucleus .....

name of particle ..... number found in nucleus .....

[2]

(ii) State one feature that is the same for the nuclei of all isotopes of uranium.

.....

..... [1]

(iii) A nucleus of  ${}^{235}_{92}\text{U}$  in a nuclear reactor can undergo nuclear fission.

Describe the process of nuclear fission in a nuclear reactor.

.....

.....

..... [2]

(iv) State one difference between nuclear fusion and nuclear fission.

.....

..... [1]

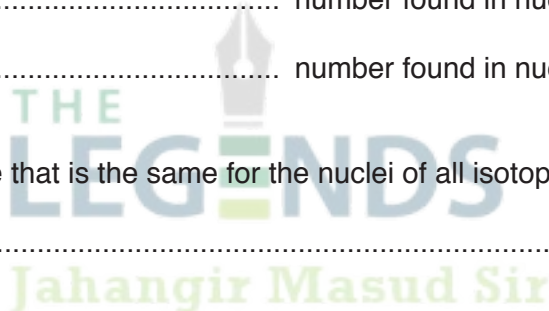

(v) The nucleus of  $^{235}_{92}\text{U}$  is not stable.

It decays by the emission of an alpha-particle ( $\alpha$ ) into a nucleus of thorium (Th).

Complete the nuclear equation that represents this decay.



(c) Geiger and Marsden carried out an experiment to investigate the scattering of alpha-particles. Fig. 11.1 shows a diagram of the apparatus that they used.

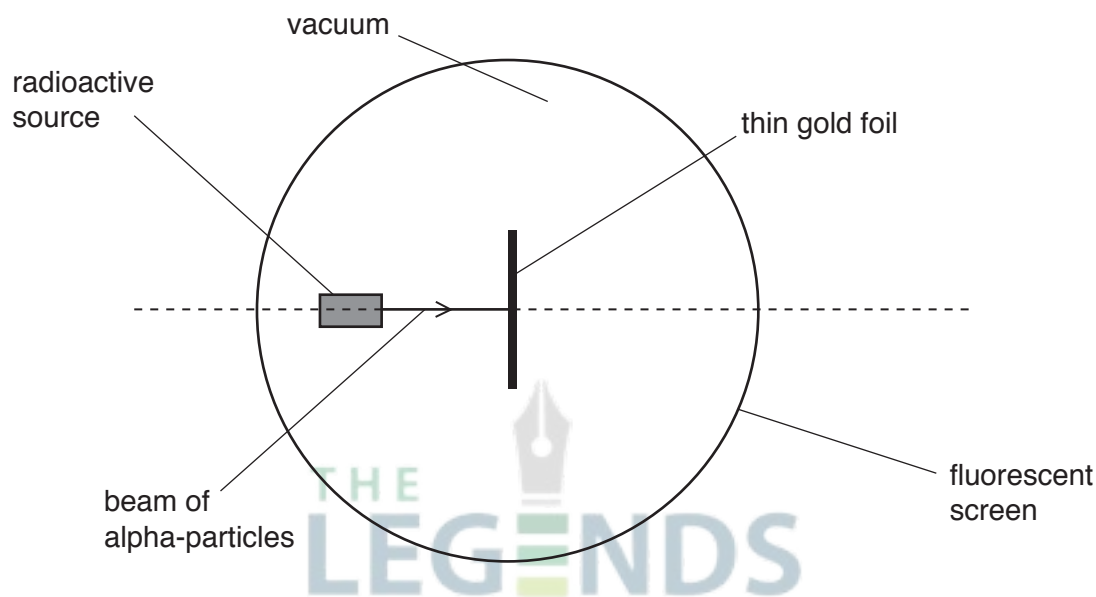

Fig. 11.1

When an alpha-particle strikes the fluorescent screen a flash of light is emitted.

(i) On Fig. 11.1, mark with a letter P where most flashes occur on the screen. [1]

(ii) Describe what is seen on the other parts of the screen.

.....  
 ..... [1]

(iii) State two conclusions about atoms of gold that resulted from this experiment.

.....  
 .....  
 ..... [2]

[Total: 15]

**PHYSICS**

Paper 1 Multiple Choice

**5054/12**

**October/November 2019**

**1 hour**

Additional Materials: Multiple Choice Answer Sheet  
Soft clean eraser  
Soft pencil (type B or HB is recommended)

**READ THESE INSTRUCTIONS FIRST**

Write in soft pencil.  
Do not use staples, paper clips, glue or correction fluid.  
Write your name, centre number and candidate number on the Answer Sheet in the spaces provided unless this has been done for you.  
**DO NOT WRITE IN ANY BARCODES**

There are **forty** questions on this paper. Answer **all** questions. For each question there are four possible answers **A, B, C** and **D**.  
Choose the **one** you consider correct and record your choice in **soft pencil** on the separate Answer Sheet.

**Read the instructions on the Answer Sheet very carefully.**

Each correct answer will score one mark. A mark will not be deducted for a wrong answer.  
Any rough working should be done in this booklet.  
Electronic calculators may be used.

This document consists of **16** printed pages.

1 Which word is the name of a vector quantity?

- A density  
 B displacement  
 C energy  
 D speed

2 What is the size of the resultant of the two forces shown in the diagram?

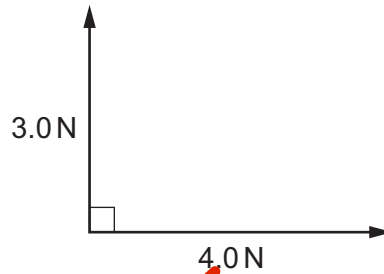

- A 1.0 N      B 3.5 N       C 5.0 N      D 7.0 N

$$\begin{aligned}
 R^2 &= P^2 + Q^2 \\
 R &= \sqrt{P^2 + Q^2} \\
 &= \sqrt{3^2 + 4^2} \\
 &= \sqrt{5^2} = 5
 \end{aligned}$$

3 What is the correct unit for the quantity shown?

|                                    | quantity                     | unit              |
|------------------------------------|------------------------------|-------------------|
| <input checked="" type="radio"/> A | electromotive force (e.m.f.) | N                 |
| <input type="radio"/> B            | latent heat                  | J                 |
| <input type="radio"/> C            | pressure                     | kg/m <sup>3</sup> |
| <input type="radio"/> D            | weight                       | kg                |

- 4 A length of copper pipe, of uniform cross-section and several metres long, carries water to a tap.

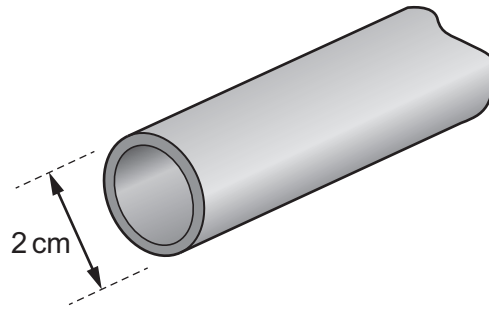

Measurements are taken to determine accurately the volume of copper in the pipe.

Which instruments are used?

- A micrometer and rule
- B micrometer and calipers
- C rule and tape
- D tape and calipers

*internal diameter → Calipers  
more than 1 metre  
→ tape.*

- 5 Part of a speed–time graph for two runners is shown. They are running along the same track.



Which statement **must** be correct?

- A Both runners started at the same moment.
- B Runner 1 has a greater acceleration than runner 2.
- C Runner 1 is moving faster than runner 2.
- D The distance between the two runners stays constant.

6 The graph shows how the speed of a car varies with time.

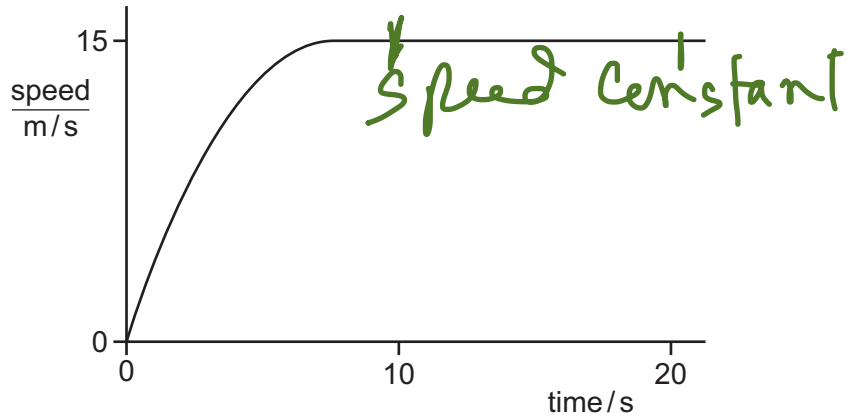

Which statement about the acceleration of the car between the times 10 s and 20 s is correct?

- A The acceleration decreases.
- B The acceleration increases.
- C The acceleration is constant, but not zero.
- D The acceleration is zero.

Jahangir Masud sir

7 In which descent is the acceleration equal to the acceleration of free fall  $g$  at all times?

- A a bungee jumper leaping from a bridge
- B a feather falling in a vertical tube that contains a vacuum
- C a hailstone travelling to Earth at terminal velocity
- D a sky-diver dropping from an aircraft towards the ground

free fall  
if there is an air resistance force then acceleration decreases

8 A body slides down a frictionless slope, as shown.

As the body presses on the surface, the surface pushes back on the body.

In which direction does the surface push back on the body?

Reaction force on contact force always act perpendicular to the surface

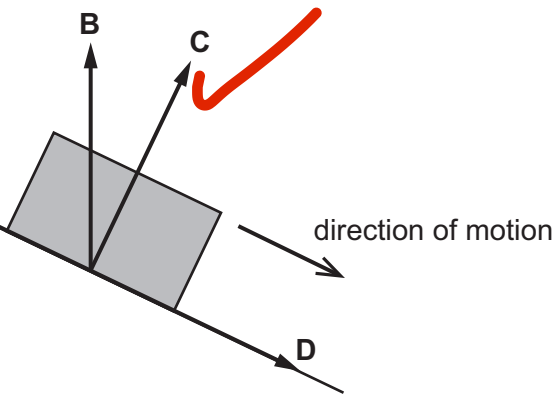

9 The Earth travels at constant speed in a circular orbit around the Sun.

You can get better idea of circular motion from this diagram

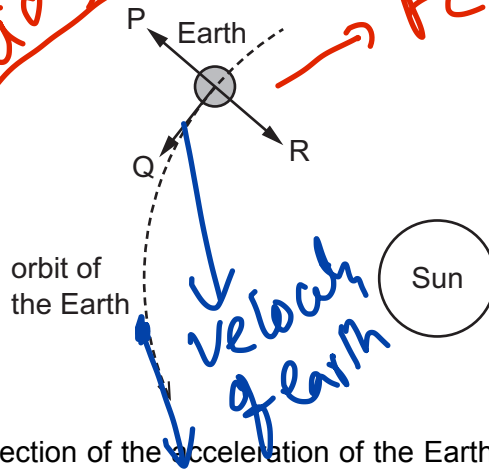

$F_c = \text{centripetal force}$

in a circular motion  $f$  and velocity perpendicular always

Which arrows show the direction of the acceleration of the Earth and the direction of the velocity of the Earth?

|          | direction of acceleration | direction of velocity |
|----------|---------------------------|-----------------------|
| <b>A</b> | P                         | Q                     |
| <b>B</b> | Q                         | P                     |
| <b>C</b> | Q                         | R                     |
| <b>D</b> | R                         | Q                     |

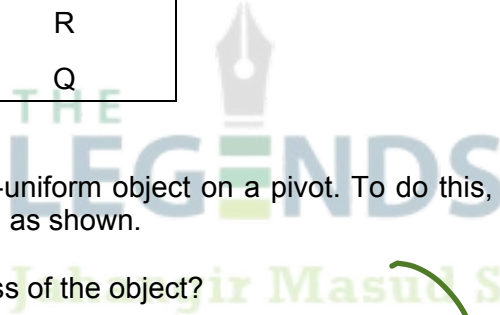

10 A student balances a non-uniform object on a pivot. To do this, a weight is suspended near the left-hand end of the object, as shown.

Where is the centre of mass of the object?

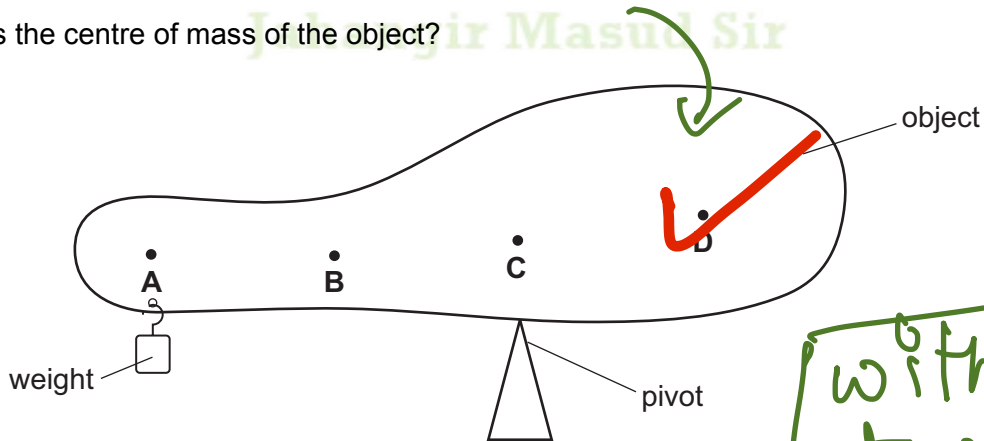

without weight it would turn on clockwise direction. it means c.g in right side for pivot

11 A load L is suspended from two springs that are in parallel. The extension of each spring is  $x$ .

In parallel load is divided among the springs so extension is  $x$

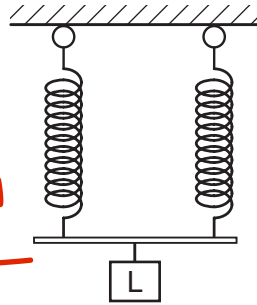

In this arrangement extension is  $x$   
 So for 1 single spring it is  $2x$   
 For two springs in series  $2x + 2x = 4x$

The springs are then arranged to hang vertically, one below the other.

In series load is not divided so both the extension must be considered

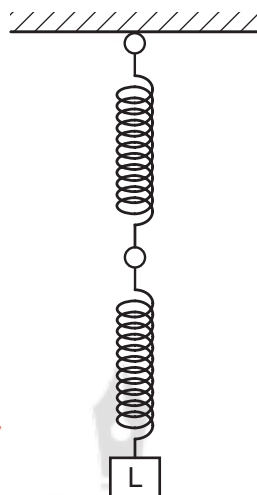

In this new arrangement, what is the total extension of the two springs?

- A  $\frac{1}{2}x$
- B  $x$
- C  $2x$
- D  $4x$

THE LEGENDS  
 Jahangir Masud Sir

12 The diagram shows three tubes P, Q and R. Each tube contains air trapped by a water column.

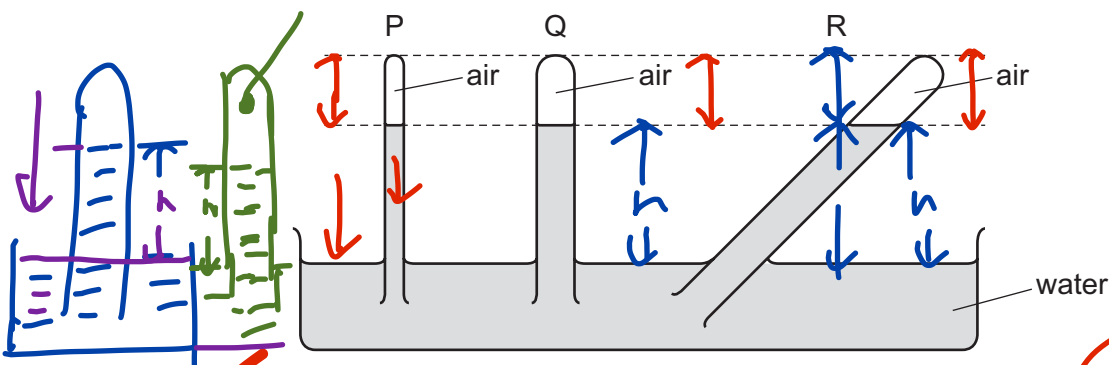

fluid pressure =  $h\rho g$

Which statement is correct?

- A The pressure of the trapped air is equal in tubes P, Q and R.
- B The pressure of the trapped air is greatest in tube Q.
- C The pressure of the trapped air is greatest in tube R.
- D The pressure of the trapped air is greatest in tube P.

$h = \text{depth of liquid}$

- 13 Which graph shows the relationship between the pressure and the volume of a fixed mass of gas at constant temperature?

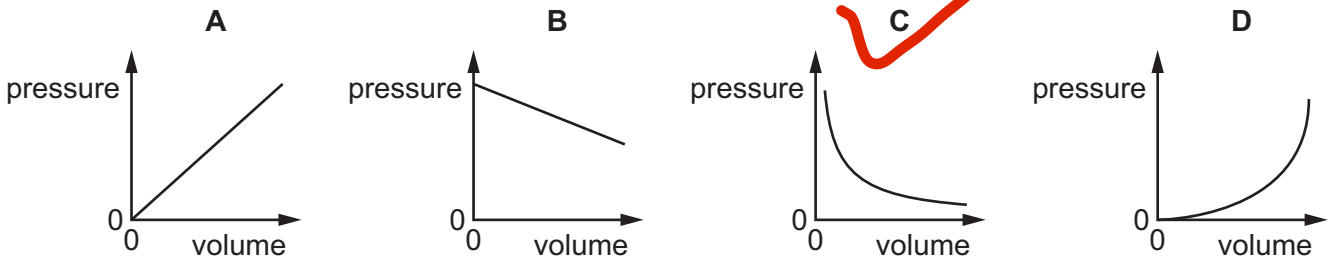

- 14 An object X has mass  $m$  and velocity  $v$ .  
A second object Y has mass  $2m$  and velocity  $2v$ .

What is the value of the ratio  $\frac{\text{kinetic energy of Y}}{\text{kinetic energy of X}}$ ?

- A 1                      B 2                      C 4                      D 8

$$p_1 v_1 = p_2 v_2$$

$$p \propto \frac{1}{v}$$

$$\frac{\frac{1}{2}(2m)(2v)^2}{\frac{1}{2}m(v)^2} = 8$$

- 15 Where is energy released by the fusion of hydrogen nuclei to form helium?

- A in a nuclear power station  
B in a radioactive isotope emitting alpha-particles  
C in the core of the Earth  
D in the core of the Sun

- 16 A student uses a newton meter to pull an object a distance  $d$  horizontally along a flat surface in a time of  $t$ . The newton meter reading is  $F$ .

What is given by the expression  $(F \times d)/t$ ?

- A efficiency  
B energy  
C power  
D work

$$P = \frac{W}{t} = \frac{F \times d}{t}$$

- 17 A student is given a thermometer that reads  $1^{\circ}\text{C}$  in pure melting ice and  $101^{\circ}\text{C}$  in pure boiling water. She uses it to measure the temperature of some water before and after it is heated.

How does the rise in temperature of the water calculated from her results compare with the correct value?

- A It is  $1^{\circ}\text{C}$  lower.  
 B It is the same.  
 C It is  $1^{\circ}\text{C}$  higher.  
 D It is  $2^{\circ}\text{C}$  higher.

$$(100^{\circ} - 0^{\circ}) = 100^{\circ}\text{C}$$

$$(101^{\circ}\text{C} - 1^{\circ}\text{C}) = 100^{\circ}\text{C}$$

Same

- 18 A student makes four statements about evaporation and boiling.

- 1 Both involve an increase in molecular separation.
- 2 Both occur only at a fixed temperature.
- 3 Both involve the absorption of thermal energy.
- 4 Both occur throughout the liquid.

Boiling only

Boiling only

Which two statements are correct?

- A 1 and 4      B 2 and 4      C 1 and 3      D 2 and 3

- 19 How is specific latent heat defined?

- A the heat absorbed or emitted by unit mass during a change of a state without a temperature change  
 B the heat absorbed or emitted by unit mass during unit temperature change  
 C the heat absorbed or emitted during a change of a state without a temperature change  
 D the heat absorbed or emitted during unit temperature change

(1 kg)

state change

No change in temp

THE LEGENDS  
 Jahangir Masud Sir

- 20 A syringe containing air is sealed at one end. The piston is free to move.

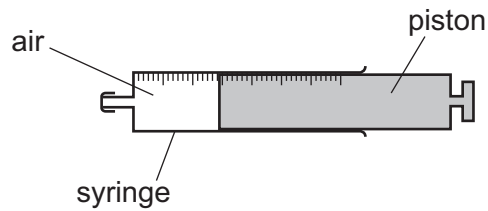

The air is heated.

What happens to the average distance between air molecules and the density of the air?

|          | average distance between air molecules | density of the air |
|----------|--|--------------------|
| <b>A</b> | increases                              | decreases          |
| <b>B</b> | increases                              | stays the same     |
| <b>C</b> | stays the same                         | decreases          |
| <b>D</b> | stays the same                         | stays the same     |

- 21 A metal disc is heated to  $600^{\circ}\text{C}$  and then lowered into a beaker of water.

What happens to the mass of the metal disc and to the mass of the water in the beaker?

|          | mass of metal disc | mass of water in beaker |
|----------|--------------------|-------------------------|
| <b>A</b> | increases          | decreases               |
| <b>B</b> | increases          | no change               |
| <b>C</b> | no change          | decreases               |
| <b>D</b> | no change          | increases               |

because of water boiling

- 22 Which description defines the amplitude of a water wave in a ripple tank?

- A** half of the vertical distance between a trough and a peak  
**B** the horizontal distance between adjacent peaks  
**C** the horizontal distance between a trough and an adjacent peak  
**D** the vertical distance between a trough and a peak

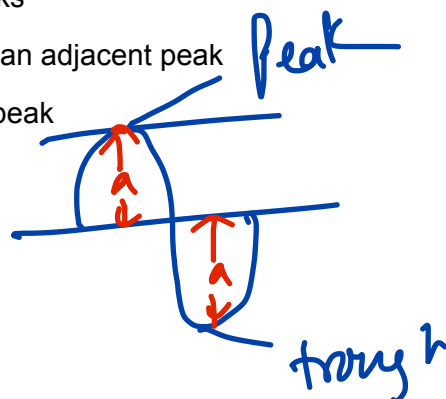



23 Here are four statements about wavefronts.

- 1 Wavefronts from a point source are straight lines. ✓
- 2 Wavefronts from a point source are circular. ✓
- 3 Wavefronts are parallel to the direction of energy movement. ✗
- 4 Wavefronts are perpendicular to the direction of energy movement.

Which two statements are correct?

- A 1 and 3      B 1 and 4      C 2 and 3      **D 2 and 4** ✓

24 An object O is placed in front of a plane mirror. I is the image formed.

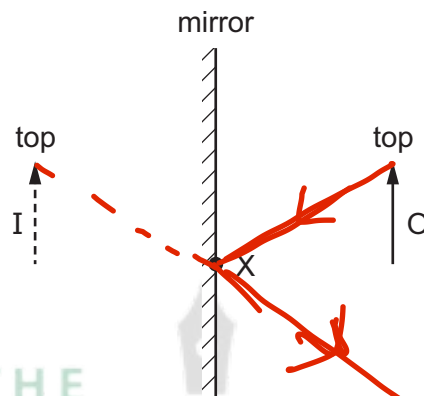

A ray from the top of the object is incident on the mirror at X.

What happens to this ray?

- A It reflects and passes through the bottom of O.
- B It reflects and passes through the top of O.
- C It reflects as though it came from the bottom of I.
- D It reflects as though it came from the top of I.** ✓

25 The diagram shows light passing from glass into air.

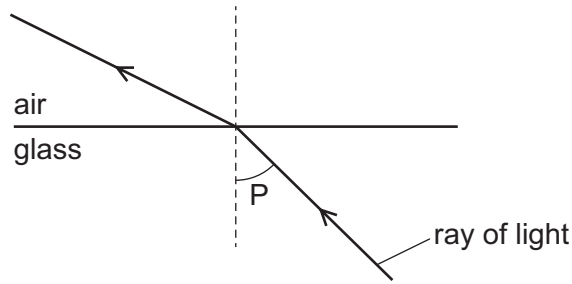

What is the name of angle P?

- A the angle of incidence
- B the angle of reflection
- C the angle of refraction
- D the critical angle

*linear magnification =  $\frac{\text{Image height}}{\text{Object height}}$*

26 An object is placed in front of a converging lens of focal length 4.0 cm. The height of the image is 6.0 cm.

The arrangement is shown on the scale diagram.

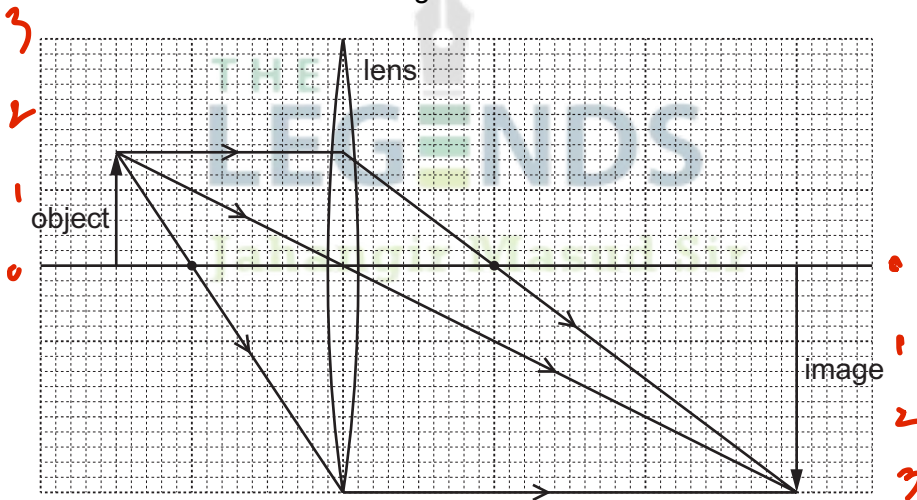

*=  $\frac{\text{Image distance}}{\text{Object distance}}$*   
*= 2.0*

What is the linear magnification produced by the lens?

- A 0.50
- B 1.5
- C 2.0
- D 6.0

27 Which row shows the speed of sound in air ( $c_a$ ), liquid ( $c_L$ ) and solid ( $c_s$ ) in order from slowest to fastest?

|   | slowest | → | fastest |
|---|---------|---|---------|
| A | $c_L$   |   | $c_s$   |
| B | $c_L$   |   | $c_s$   |
| C | $c_a$   |   | $c_s$   |
| D | $c_s$   |   | $c_a$   |

28 A man stands 80 m in front of a cliff face. He makes a loud bang and listens for the echo.

He makes a loud bang once every second. He hears an echo exactly halfway between the bang that caused it and the next bang.

What is the speed of sound?

- A 40 m/s      B 80 m/s      C 160 m/s      D 320 m/s

$t = 0.5s$

29 The diagram shows two magnetic field lines of the magnetic field around two bar magnets

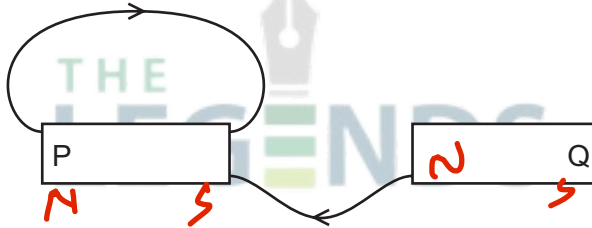

$v = \frac{d}{t}$   
 $= \frac{160 \text{ ms}}{0.5}$   
 $= 320 \text{ ms}^{-1}$

Which row shows the magnetic poles at end P and end Q of the two magnets?

|   | P | Q |
|---|---|---|
| A | N | N |
| B | N | S |
| C | S | N |
| D | S | S |

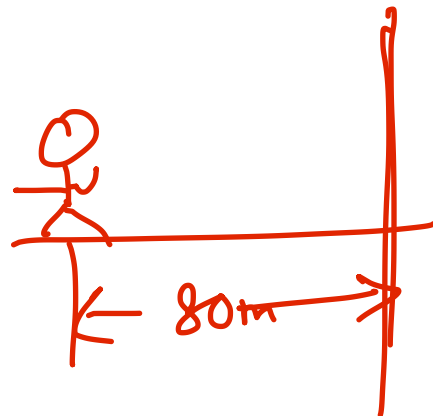

30 A metal plate X is attached to earth by a battery. The plate has a positive charge.

A second metal plate Y is initially uncharged and connected to earth. This plate is positioned parallel to X.

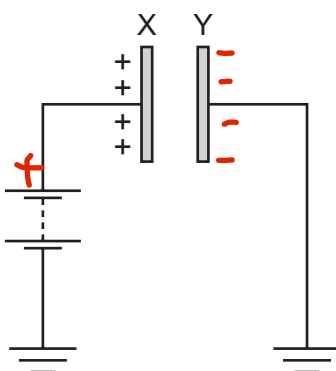

What happens as Y is brought closer to X?

- A Electrons flow from Y to earth only.
- B Electrons flow to Y from earth only.
- C Protons flow from Y to earth and electrons flow to Y from earth.
- D Protons flow to Y from earth and electrons flow from Y to earth.

31 The diagram shows a metal lightning conductor attached to a building.

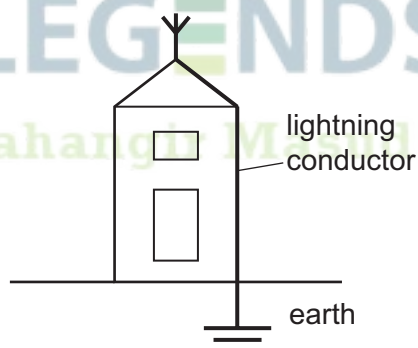

Why is the lightning conductor made of copper?

- A Both positive and negative charges can flow through copper.
- B Copper can be electrostatically charged.
- C So the lightning conductor has a low electrical resistance.
- D So the heat is conducted away quickly.

32 Which symbol does **not** represent a power source?

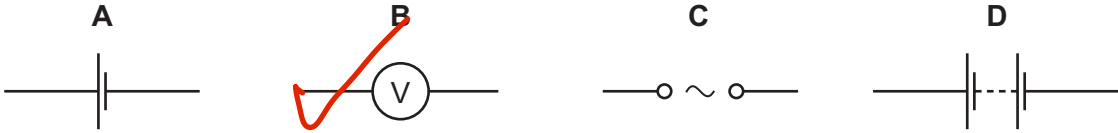

33 Resistors of different resistances are connected to a power supply in either a parallel circuit or a series circuit. Which statement is correct?

- A The current is the same in all resistors connected in parallel.
- B The current is the same in all resistors connected in series.
- C The voltage across each resistor is different for all resistors connected in parallel.
- D The voltage across each resistor is the same for all resistors connected in series.

*# In series (I) always same*  
*# In parallel circuit (V) always remains same*

34 An ammeter is connected to three resistors and a power supply.

Which arrangement of resistors gives the greatest ammeter reading?

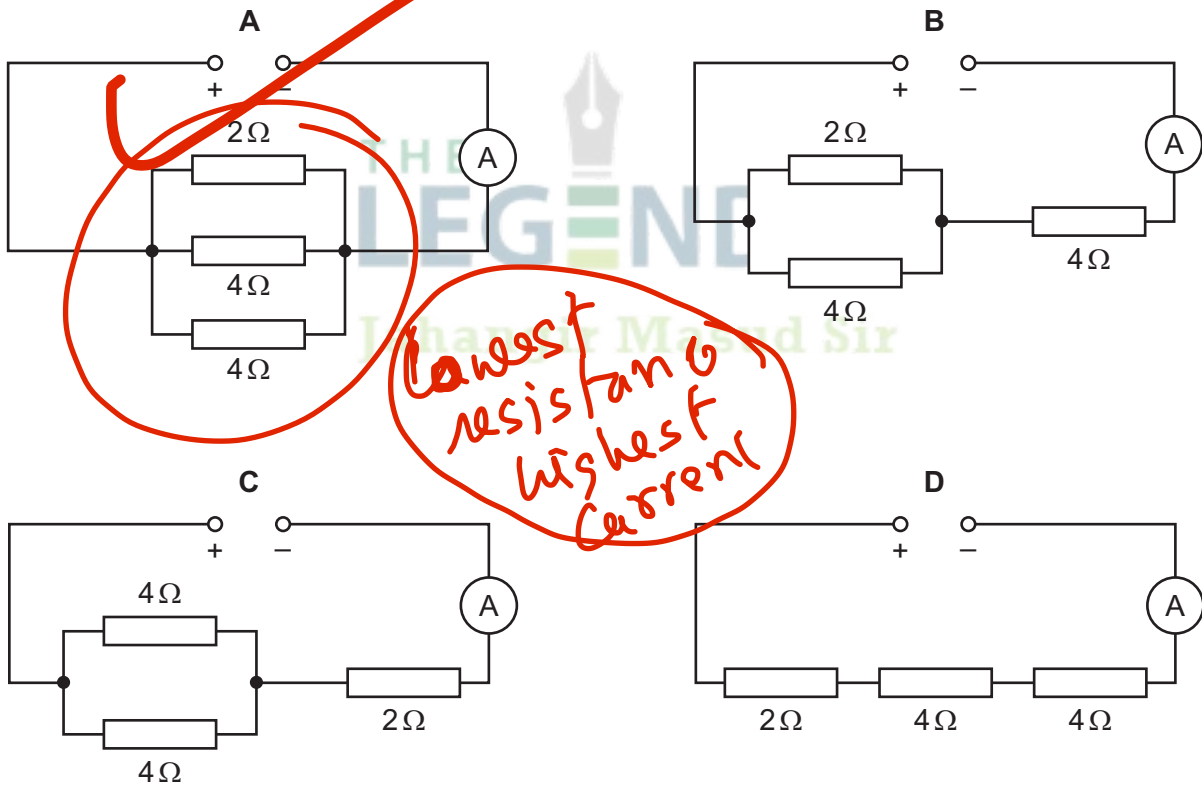

*lowest resistance, highest current*

35 A hotplate on an electric cooker contains two identical resistors.  
The switch has three positions.

- position 1 The two resistors are connected in series to the mains supply.
- position 2 The two resistors are connected in parallel to the mains supply
- position 3 Just one resistor is connected to the mains supply.

Which positions correspond to the low, the medium and the high power settings?

|   | low power | medium power | high power |
|---|-----------|--------------|------------|
| A | 1         | 2            | 3          |
| B | 1         | 3            | 2          |
| C | 3         | 1            | 2          |
| D | 3         | 2            | 1          |

medium

Resistance highest

lowest current

low power

highest current

Resistance decreases

high power

36 A mains electric circuit is fitted with a circuit breaker rather than a fuse.

Where is the circuit breaker connected and what happens when the current is too large?

|   | A circuit breaker is connected in... | When the current is too large...          |
|---|--------------------------------------|---|
| A | the live wire.                       | a thin wire melts and breaks the circuit. |
| B | the live wire.                       | an electromagnet opens a switch.          |
| C | the neutral wire.                    | a thin wire melts and breaks the circuit. |
| D | the neutral wire.                    | an electromagnet opens a switch.          |

# circuit breaker  
# fuse  
# switch

all will be connected with live wire

37 Transformers are used to transmit electrical energy between power stations and transmission cables, as shown.

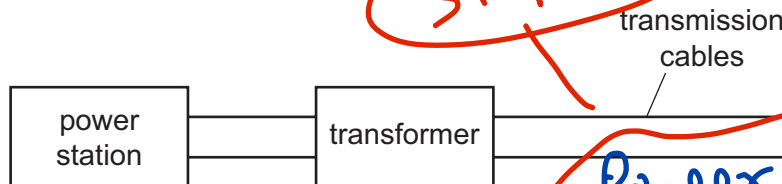

step up

What is the purpose of the transformer in the diagram?

- A to decrease the current and the potential difference from the power station
- B to decrease the current and increase the potential difference from the power station
- C to increase the current and the potential difference from the power station
- D to increase the current and decrease the potential difference from the power station

Power is transmitted through overhead wire with high voltage so step up for safety in use

Rate of increase in current decreases

increase in current decreases

38 A thermistor warms up as the current in it increases.

Which graph shows how the voltage  $V$  across the thermistor changes as the current  $I$  through it is increased?

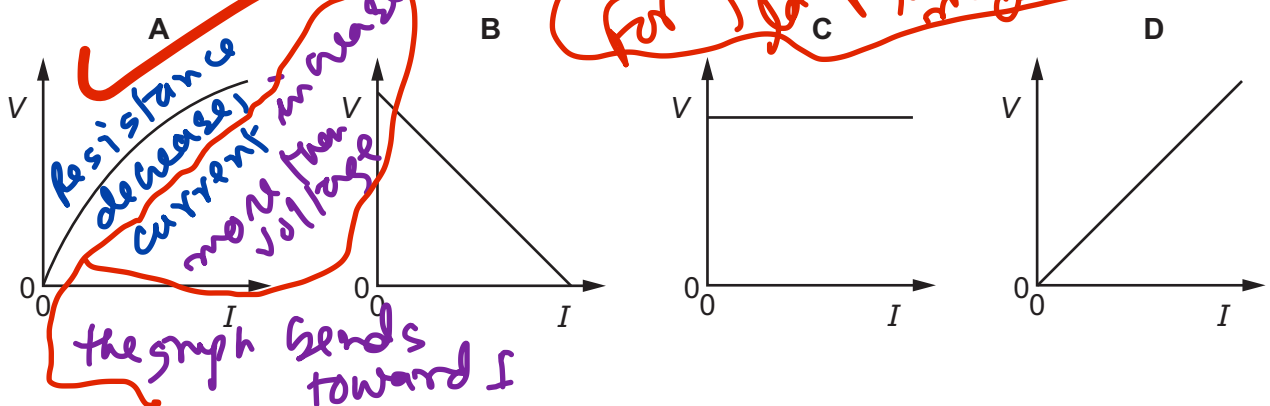

39 Radioactive substances are used as tracers in medical examinations.

A liquid tracer is injected into a patient. A detector 20 cm above the patient shows where the radioactive substance is in the body.

What is the best radioactive substance to use?

- A an alpha-particle emitter with a half-life of a few hours
- B an alpha-particle emitter with a half-life of a few years
- C a gamma ray emitter with a half-life of a few hours
- D a gamma ray emitter with a half-life of a few years

# less half life for destroy or inactive soon  
# More penetration power

40 An isotope of lead,  $^{212}_{82}\text{Pb}$ , is radioactive. After three decays, two beta-particles and an alpha-particle have been emitted. Another radioactive isotope of lead is formed.

What is the mass number (nucleon number) of the new isotope of lead?

- A 200
- B 208
- C 212
- D 216

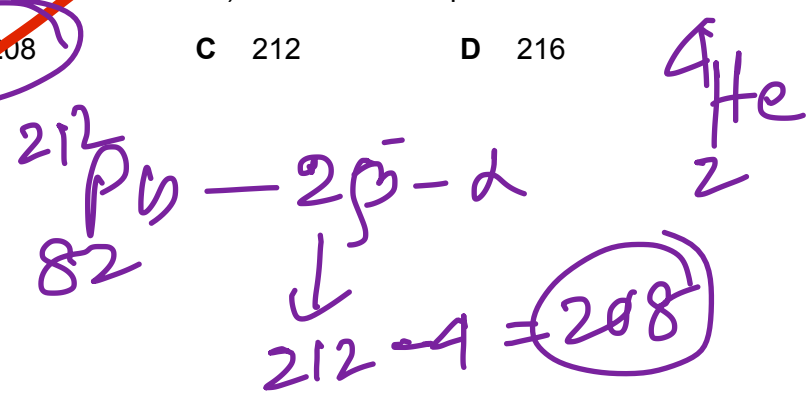

Permission to reproduce items where third-party owned material protected by copyright is included has been sought and cleared where possible. Every reasonable effort has been made by the publisher (UCLES) to trace copyright holders, but if any items requiring clearance have unwittingly been included, the publisher will be pleased to make amends at the earliest possible opportunity.

To avoid the issue of disclosure of answer-related information to candidates, all copyright acknowledgements are reproduced online in the Cambridge Assessment International Education Copyright Acknowledgements Booklet. This is produced for each series of examinations and is freely available to download at www.cambridgeinternational.org after the live examination series.

Cambridge Assessment International Education is part of the Cambridge Assessment Group. Cambridge Assessment is the brand name of the University of Cambridge Local Examinations Syndicate (UCLES), which itself is a department of the University of Cambridge.

Cambridge  
**O Level**

Cambridge Assessment International Education  
Cambridge Ordinary Level

CANDIDATE  
NAME

CENTRE  
NUMBER

CANDIDATE  
NUMBER

**PHYSICS**

Paper 2 Theory

5054/22

October/November 2019

1 hour 45 minutes

Candidates answer on the Question Paper.

No Additional Materials are required.

**READ THESE INSTRUCTIONS FIRST**

Write your centre number, candidate number and name on all the work you hand in.

Write in dark blue or black ink.

You may use an HB pencil for any diagrams or graphs.

Do not use staples, paper clips, glue or correction fluid.

DO **NOT** WRITE IN ANY BARCODES.

**Section A**

Answer **all** questions.

Write your answers in the spaces provided on the Question Paper.

**Section B**

Answer any **two** questions.

Write your answers in the spaces provided on the Question Paper.

Electronic calculators may be used.

You may lose marks if you do not show your working or if you do not use appropriate units.

At the end of the examination, fasten all your work securely together.

The number of marks is given in brackets [ ] at the end of each question or part question.

This document consists of **18** printed pages and **2** blank pages.

## Section A

Answer **all** the questions in this section. Answer in the spaces provided.

- 1 There is no atmosphere on the Moon.

An astronaut on the Moon drops a feather and a hammer from the same height at the same time. They both accelerate downwards at  $1.6 \text{ m/s}^2$  and they hit the ground at the same time.

- (a) The weight of the hammer is much larger than that of the feather.

Explain, in terms of their weights and masses, why their accelerations are equal.

Weight is directly proportional to mass  
 or  $W = mg$   
 More massive object is exerted  
 by large force and less massive  
 object is exerted by less force  
 $a = \frac{F}{m}$ , force mass ratio is  
 same for falling body. so acceleration  
 is same. [3]

Jahangir Masud sir

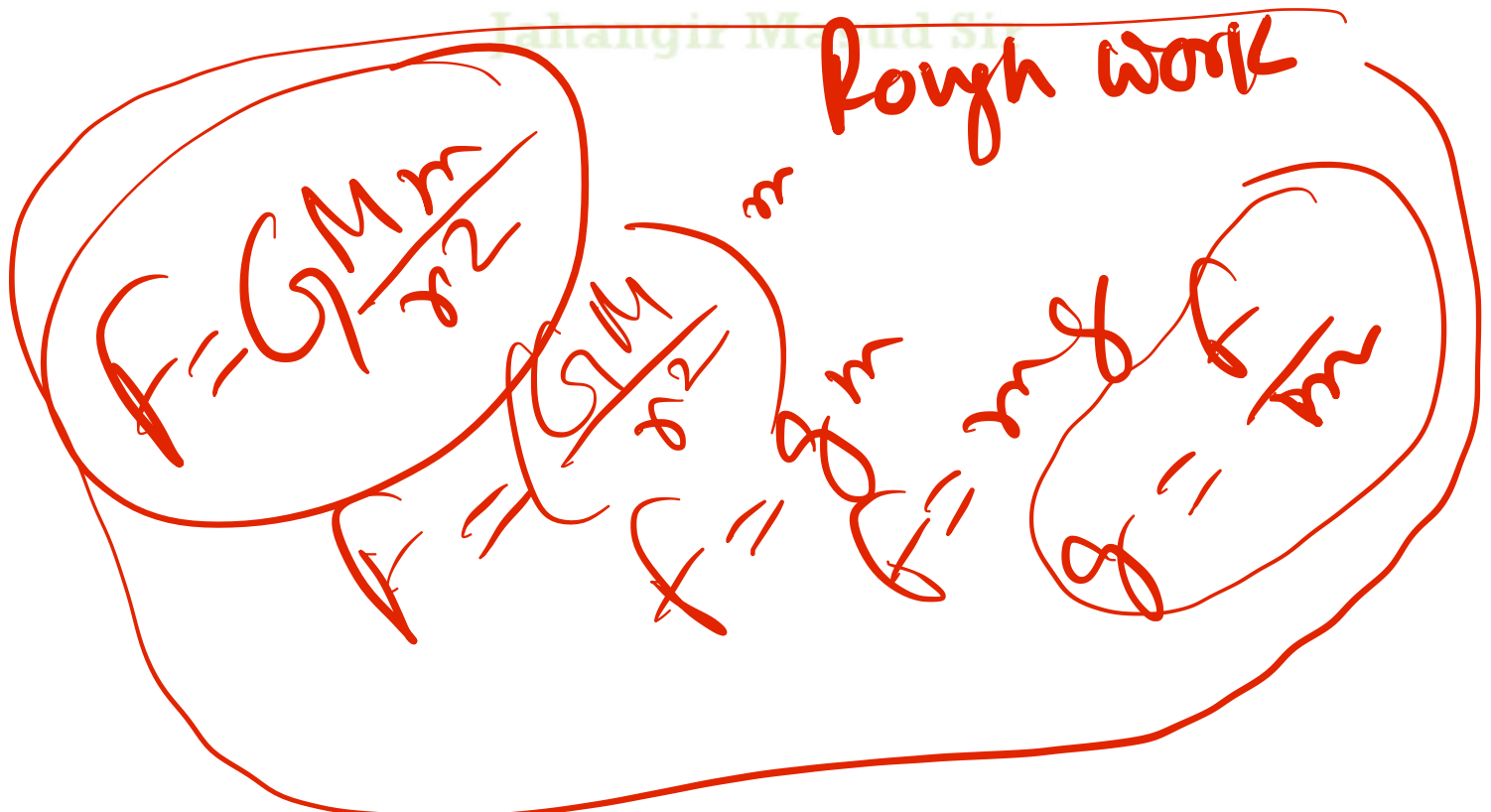

rest,  $u=0$

$a = \frac{v-u}{t}$   
 $v-u=at$   
 $v=at$

(b) Both the feather and the hammer take 1.5s to fall to the ground from rest.

(i) Calculate the speed of the objects as they hit the ground.

$v \propto t$

$v = u + gt$   
 $v = 0 + 9.8 \times 1.5 = 14.7 \text{ m/s}$

speed = ..... [2]

(ii) On Fig. 1.1, draw the speed-time graph for the fall. At the correct position on the y-axis, write the value of the speed at time  $t = 1.5$ s.

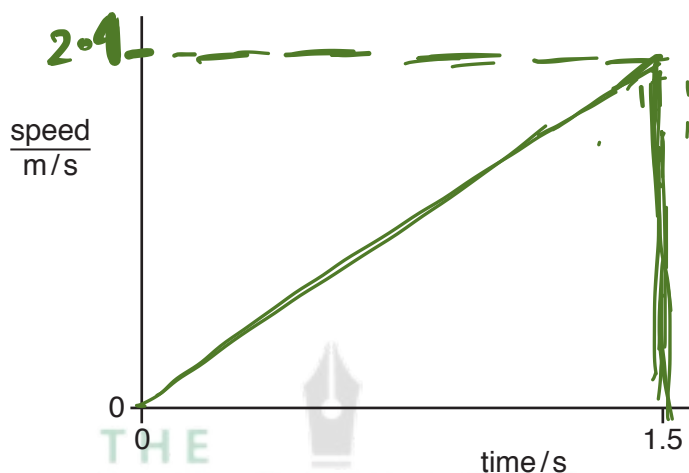

$v = gt$   
 $g$  is constant  
 $v \propto t$

Fig. 1.1

[1]

(iii) Using the speed-time graph in (b)(ii), determine the height from which the objects are dropped.

Area under the graph  
 $= \frac{1}{2} \times 1.5 \times 2.4$

height = ..... [2]

$= 1.8 \text{ m.}$

[Total: 8]

- 2 A student uses a pump to inflate a bicycle tyre.

Fig. 2.1 shows the pump and the tyre.

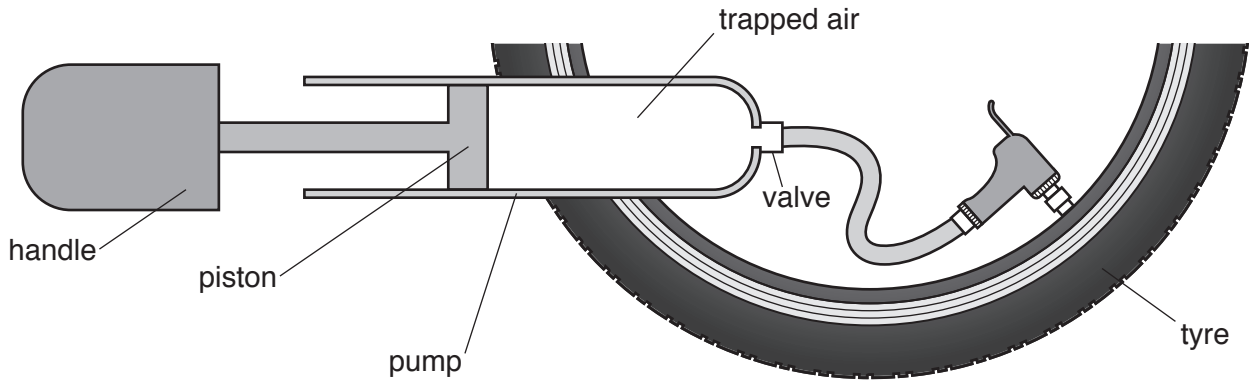

Fig. 2.1 (not to scale)

- (a) The pressure of the trapped air in the pump is  $3.8 \times 10^5 \text{ Pa}$  and the cross-sectional area of the piston is  $6.1 \times 10^{-4} \text{ m}^2$ .
- (i) Calculate the force exerted on the piston by the trapped air in the pump.

$$\begin{aligned}
 F &= PA \\
 &= 3.8 \times 10^5 \times 6.1 \times 10^{-4} \\
 &= 230 \text{ N}
 \end{aligned}$$

force = ..... [2]

- (ii) The student pushes the handle to the right and the piston forces the trapped air into the tyre. The force exerted by the student is less than the value in (a)(i).

Suggest one reason why.

pressure of trapped gas decreases as valve opens

..... [1]

Jahangir Masud sir

- (b) The temperature of the air in the pump remains constant as the handle moves to the right.

Explain, in terms of its molecules, why the pressure of a gas increases when its volume is decreased at constant temperature.

Molecules collide each other and hit on the wall. As total volume decreases so the number of molecules per unit volume increases, therefore the frequency of collision increases and pressure increases

..... [3]

[Total: 6]

3 Solar panels are used to heat water.

(a) The energy absorbed by solar panels comes from the Sun.

(i) Describe how this energy is produced inside the Sun.

By nuclear fusion where small nuclei  
fuse together and produce a larger  
nucleus with the release of energy. [2]

(ii) State how this energy is transferred to Earth.

By infrared radiation [1]

(b) Explain why solar panels are usually black.

Black surfaces are good absorbers  
of infrared radiation.

[2]

[Total: 5]



- 4 In many countries, solid salt is produced by trapping sea-water in large, shallow ponds and letting the water evaporate.

Fig. 4.1 shows salt being produced in this way.



Fig. 4.1

- (a) State two ways in which evaporation differs from boiling.

1. Evaporation occurs at surface  
Boiling occurs at whole depth of liquid

2. Evaporation occurs at any temperature  
Boiling occurs at fixed temperature

[2]

- (b) Describe, in terms of water molecules, what is happening as the water evaporates.

High energetic molecules escape from the surface of liquid leaving behind low energetic molecules. Average kinetic energy of the remaining liquid decreases which decreases the temperature of the liquid.

[2]

- (c) (i) State why the ponds used in this process have large surface areas.

Rate of evaporation increases with increasing surface area.

[1]

- (ii) State why this method of salt production does not work well in a country with a cold climate.

Rate of evaporation decreases with decreasing temperature.

[1]

[Total: 6]

5 Both sound and ultrasound are longitudinal waves.

Particles

(a) Describe what is meant by *longitudinal*.

Direction of vibrations of medium are parallel to the direction of energy travel

[2]

(b) Fig. 5.1 shows an ultrasound cleaner being used to clean jewellery.

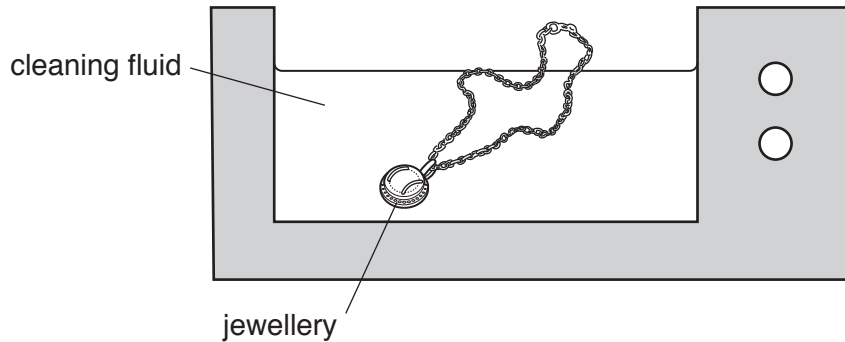

Fig. 5.1

The jewellery is lowered into the cleaning fluid and ultrasound waves of frequency 42 000 Hz are produced in the fluid.

(i) The speed of ultrasound in the fluid is 1500 m/s.

Calculate the wavelength of the ultrasound in the fluid.

$$\lambda = \frac{v}{f} = \frac{1500}{42000} = 0.036 \text{ m}$$

wavelength = ..... [2]

(ii) Describe how the ultrasound cleans the jewellery.

Ultrasound and cleaning fluid jointly vibrates and create bubbles that cling to foreign particles. Dirt is taken off by the fluid.

[2]

[Total: 6]

6 An electric circuit contains a  $700\ \Omega$  resistor and a light-dependent resistor (LDR). Fig. 6.1 is the circuit diagram.

*Current across  $700\ \Omega$  = across LDR as they are in series connection*

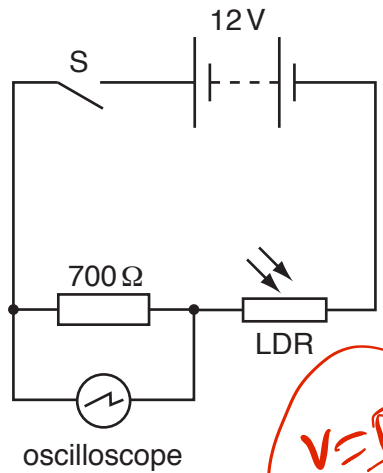

$$I = \frac{V}{R} = \frac{4}{700} \text{ A}$$

*$V = IR$   
 $V \uparrow = IR \text{ constant}$*

Fig. 6.1

The electromotive force (e.m.f.) of the battery is 12 V.

An oscilloscope is connected across the fixed resistor. Fig. 6.2 shows the oscilloscope, including the settings of the timebase and the Y-gain controls. Line Q shows the position of the trace on the oscilloscope when the switch S is open.

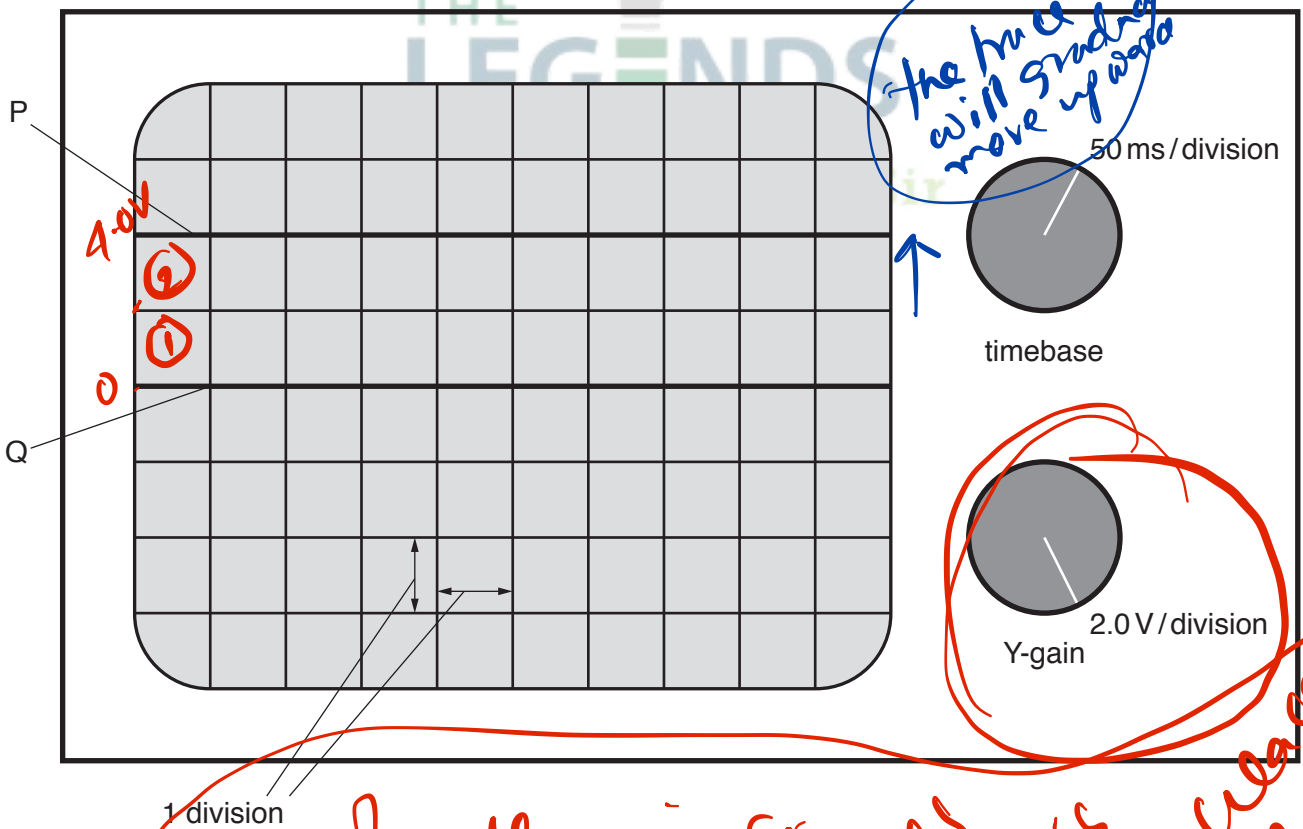

*the  $h\nu$  will gradually move up ward*

1 division

Fig. 6.2

*# LDR resistance decreases - current in the circuit ceases # pd across  $700\ \Omega$  increases - line will gradually move upward*

The switch S is closed and the trace on the oscilloscope moves to the position shown by line P in Fig. 6.2.

- (a) (i) Determine the potential difference (p.d.) across the  $700\ \Omega$  resistor.

p.d. =  $4.0\text{ V}$  ..... [1]

- (ii) Determine the resistance of the LDR.

p.d. across LDR =  $12 - 4 = 8\text{ V}$ .

$$v = IR$$

$$\therefore R = \frac{v}{I} = \frac{8}{\frac{4}{700}} = 1400\ \Omega$$

resistance = ..... [3]

- (b) The intensity of the light incident on the LDR gradually increases.

State and explain how the trace on the oscilloscope screen moves.

Resistance of LDR decreases  
 Current increases, p.d. across  $700\ \Omega$  resistor  
 increases - trace moves up the screen.

..... [3]

[Total: 7]

7 Fig. 7.1 shows a horizontal, rectangular coil ABCD placed between a magnetic N-pole and an S-pole.

There is a current in the coil.

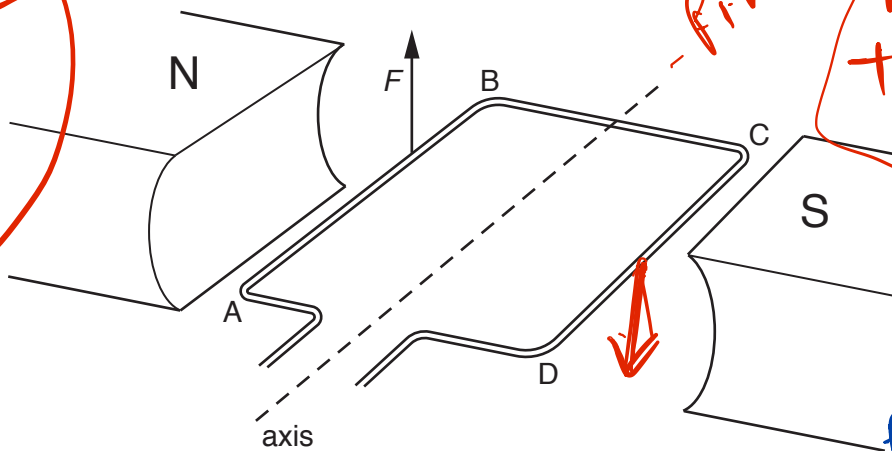

Fig. 7.1

An upward force  $F$  of size  $9.6 \times 10^{-3} \text{ N}$  acts on side AB of the coil.

(a) (i) Explain why there is a force on side AB.

magnetic field and current interact each other produces this force. [1]

(ii) Determine the direction of the current in AB and state how the direction is deduced.

According to Fleming's left hand rule fore finger  $\rightarrow$  magnetic field (N to S) thumb  $\rightarrow$  motion up ward, so the finger current from B to A. [2]

(b) Both side AB and side CD of the coil are 2.5 cm from the axis.

Determine the total moment acting on the coil.

$$2 \times 9.6 \times 10^{-3} \times 2.5 \times 10^{-2}$$

$$4.8 \times 10^{-4} \text{ Nm}$$

moment = ..... [2]

(c) The coil in Fig. 7.1 is part of a direct current (d.c.) motor.

(i) State the name of the device that connects the coil of a d.c. motor to the electricity supply.

split ring commutator. [1]

(ii) State one change to the arrangement in Fig. 7.1 that produces a greater turning effect in coil ABCD.

using stronger magnet. [1]

[Total: 7]

# AC Generator

# Rotation  
# Slip rings  
Direct (+) process

Alternation (-)

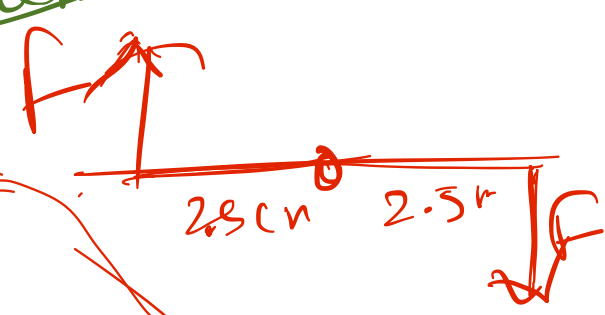
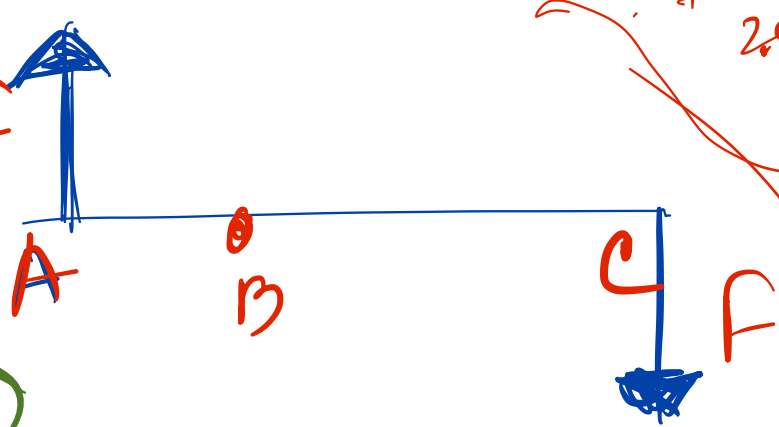

$$\begin{aligned}
 &F \times AB + F \cdot BC \\
 &= F(AB + BC) \\
 &= F \times AC
 \end{aligned}$$

Section B begins over the page

One force  $\times$  the perpendicular distance between two forces

$$9.6 \times 10^{-3} \times 2 \times 2.5$$

Rotation of coil  $\Rightarrow$  Alternating process (+)  
# Split ring reverses Alternation process (-)

Direct Current Motor  
DC motor (+)

## Section B

Answer **two** questions from this section. Answer in the spaces provided.

- 8 Fig. 8.1 shows an elastic rope (bungee).

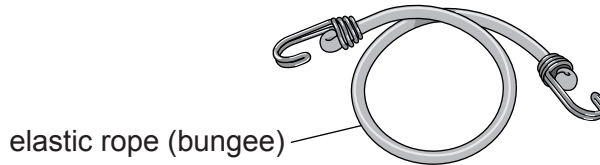

Fig. 8.1

The unstretched length of the rope is 0.80 m.

A student uses the hook at one end to suspend the rope from a shelf and hangs an empty paint can of mass 0.70 kg from the other end. The rope stretches to a length of 0.97 m but does not exceed its limit of proportionality.

- (a) Explain what is meant by *limit of proportionality*.

limit of proportionality is a point above where the extension is no longer proportional to load.

- (b) State what is meant by:

- (i) *mass*... Amount of matter in a body [1]
- (ii) *weight*... force of attraction in a gravitational field. [2]

- (c) The gravitational field strength is 10 N/kg.

- (i) Calculate the weight of the empty paint can.

$$W = mg = 0.7 \times 10 \text{ N} \quad \text{weight} = 7.0 \text{ N} \quad [1]$$

- (ii) For the rope, calculate a value for  $\frac{\text{load}}{\text{extension}}$ .
- $$\frac{7.0}{(0.97 - 0.80)} = \frac{F}{x} \Rightarrow \frac{F}{x} = k = 0.41 \text{ N/cm} \quad [1]$$

extension = k x mass  
~~F = k x~~

(d) The student repeatedly pours small volumes of paint into the can.

When there is  $2.5 \times 10^{-3} \text{ m}^3$  of paint in the can, the total length of the rope is 1.70 m. This is where the rope reaches the limit of proportionality.

(i) Determine the mass of the paint in the can.

$w = mg$   
 $\text{Mass} = \frac{w}{g}$   
 $= \frac{29.9}{10}$   
 $= 2.99$   
 $\approx 3.0 \text{ kg}$

extension =  $1.70 - 0.80 = 0.90 \text{ m}$   
 $F = kx$   
 $\text{or } F = 41 \times 0.90 = 36.9 \text{ N}$   
 paint =  $(36.9 \text{ N} - 7.0 \text{ N}) = 29.9 \text{ N}$

mass = ..... [3]

(ii) The student continues to pour paint into the can until there is a volume of  $5.0 \times 10^{-3} \text{ m}^3$  in it. He notices that the elastic rope becomes harder to stretch after the limit of proportionality.

He plots a graph of the total length of the rope against the volume of paint added.

On Fig. 8.2, sketch the length-volume graph for the range 0 to  $5.0 \times 10^{-3} \text{ m}^3$ .

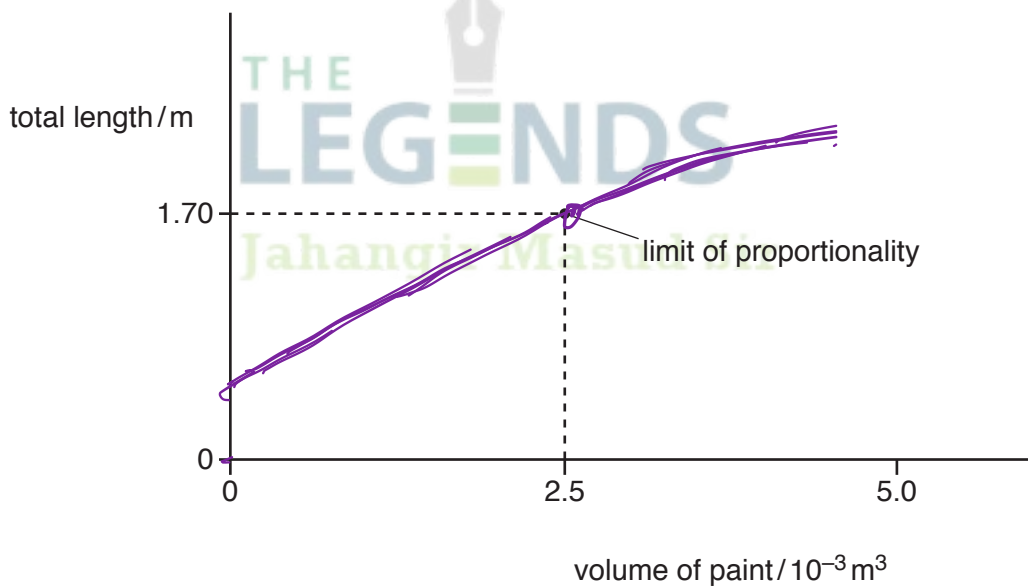

Fig. 8.2

[3]

(e) The student suddenly removes the can from the end of the stretched rope and, as it contracts, the rope jumps into the air.

State the energy change that is taking place in the rope as it contracts and jumps into the air.

Elastic potential energy to kinetic energy.

[2]

[Total: 15]

9 Fig. 9.1 shows a boiling liquid at its boiling point, trapped in a cylinder by a piston.

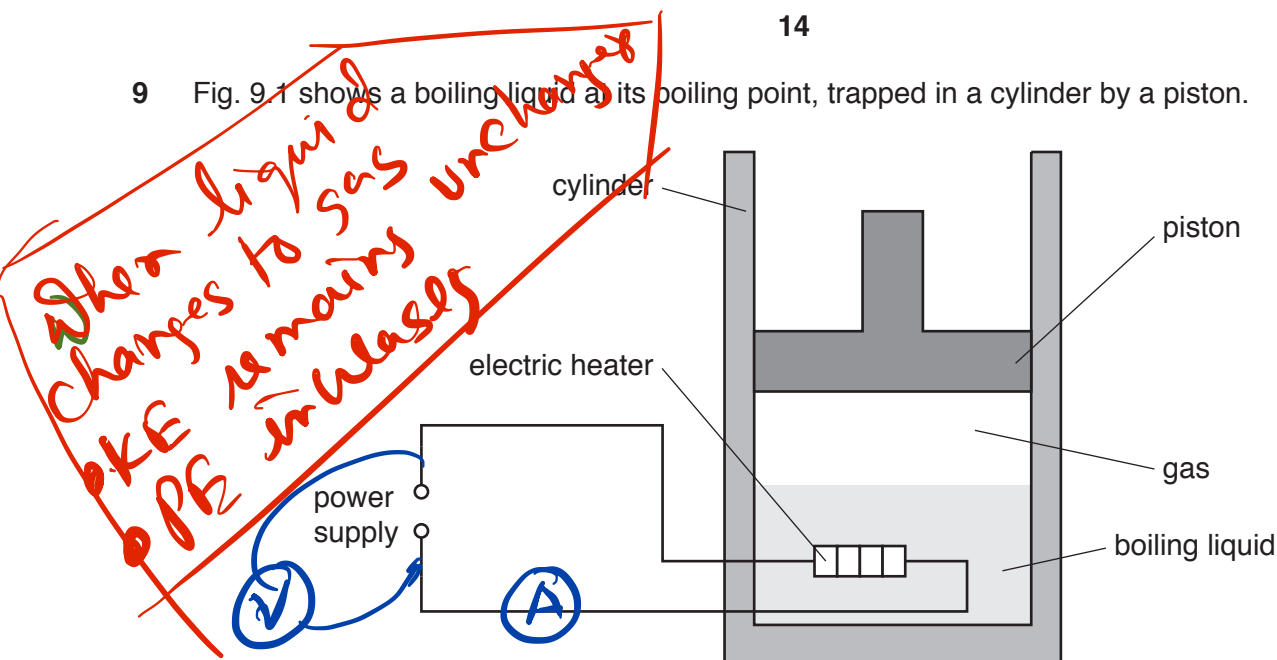

Fig. 9.1

There is an electric heater in the liquid which is connected to a power supply. The thermal energy produced by the heater gradually turns the boiling liquid into a gas.

(a) State what is meant by *boiling point*.

The fixed temperature at which a liquid converts into a gas. [2]

(b) Explain, in terms of molecules, why it is necessary to supply energy in order to turn a liquid at its boiling point into a gas.

Work must be done to break the bonds of liquid and to separate molecules that is to increase the potential energy. [3]

(c) In order to determine the power of the electric heater, two meters are connected into the circuit. One meter measures the current in the heater and the other meter measures the potential difference (p.d.) across it.

On the circuit in Fig. 9.1, draw symbols to show the two meters used and where they are connected. [2]

(d) The current in the heater is 2.0A and the p.d. across it is 6.0V.

(i) Calculate the power of the heater.

$$P = VI$$

$$= 6.0 \times 2.0 \text{ A} = 12 \text{ W}$$

power = ..... [2]

(ii) Calculate the thermal energy supplied to the liquid by the heater in 1.0 minute.

12 W → 12 J in 1 second

$$\text{energy} = P \times t = 12 \times 60$$

$$= 720 \text{ J}$$

energy = ..... [2]

(iii) The specific latent heat of vaporisation of the liquid is  $9.0 \times 10^5 \text{ J/kg}$ .

Calculate the mass of liquid that vaporises every minute.

$$Q = mL_v \Rightarrow m = \frac{Q}{L_v} = \frac{720}{9.0 \times 10^5}$$

$$= 8.0 \times 10^{-4} \text{ kg}$$

mass = ..... [2]

(e) The piston is free to move in the cylinder. As the liquid boils, the piston is pushed upwards in the cylinder at a constant speed. The volume occupied by the gas just above the liquid increases.

Discuss whether the upward force on the piston changes as the piston moves upwards at constant speed.

Resultant force is zero as the weight of piston plus force due to atmospheric pressure equal to upward force

[2]

When constant speed  
Resultant force is zero  
the object is in equilibrium

[Total: 15]

10 All the isotopes of the gas radon are radioactive.

(a) State **one** similarity and **one** difference between the nuclei of two different isotopes of radon.

similarity ..... *same number of protons* .....

difference ..... *different no. of neutrons* .....

[2]

(b) The isotope radon-222 decays by alpha-particle emission to an isotope of polonium (Po). The proton number (atomic number) of polonium is 84.

(i) Determine the number of neutrons in an atom of the polonium isotope.

*mass no of (Po) 222 - 4 = 218*

*neutron no. = 218 - 84 = 134*

number of neutrons = ..... [2]

(ii) Determine the number of protons in an atom of radon-222.

*84 + 2 = 86*

number of protons = ..... [2]

(iii) Describe how a neutral atom of helium ( ${}^4_2\text{He}$ ) differs from an alpha-particle.

*( ${}^4_2\text{He}$ ) Helium atom has two electrons*

*Alpha particle doesn't have electrons ( ${}^4_2\text{He}^{++}$ )*

[1]

- (c) In an experiment to collect a small quantity of helium, a sample of radon-222 is enclosed in an inner glass tube which has a very thin wall. Fig. 10.1 shows that this tube is placed inside a container that is initially evacuated.

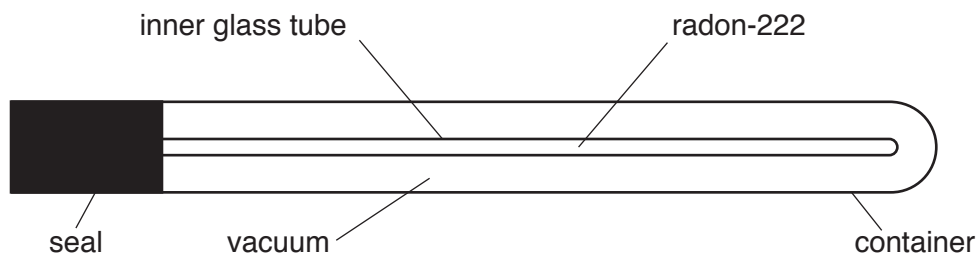

Fig. 10.1

Both the container and the inner glass tube are sealed.

As the radon-222 decays, alpha-particles pass through the thin wall of the inner glass tube.

Fig. 10.2 shows how the total number of alpha-particles produced by the radioactive decay of the radon-222 changes as time passes.

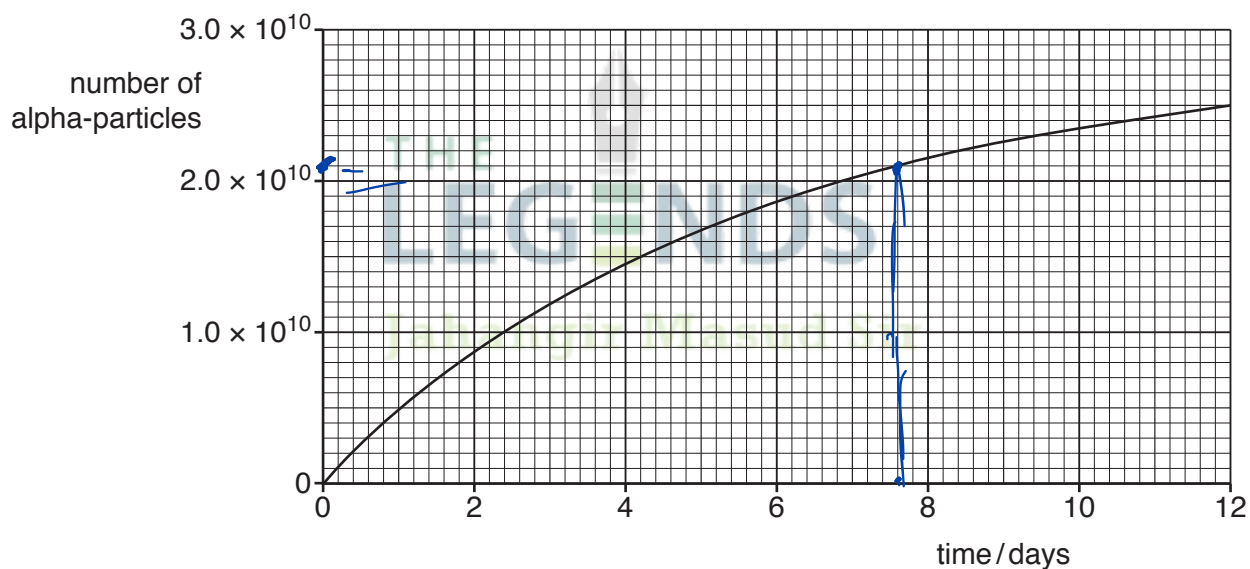

Fig. 10.2

- (i) Use Fig. 10.2 to determine the number of alpha-particles produced in 7.6 days.

.....  $2.1 \times 10^{10}$  [1]

- (ii) Initially, there are  $2.8 \times 10^{10}$  atoms of radon-222 in the inner glass tube. As each radon-222 atom decays, it produces an alpha-particle.

Calculate the number of radon-222 atoms that remain after 7.6 days.

$$2.8 \times 10^{10} - 2.1 \times 10^{10} = 0.7 \times 10^{10} = 7.0 \times 10^9$$

number of atoms remaining = ..... [1]

- (iii) Using the number of radon-222 atoms present initially and the number present after 7.6 days, calculate the half-life of radon-222.

$$\frac{7.0 \times 10^9}{2.8 \times 10^{10}} = \frac{1}{4}$$

= 2 half lives

$$\frac{2.8 \times 10^{10}}{7.0 \times 10^9} = 4$$

2 half lives  $\rightarrow$  7.6 days

half-life =  $T_{1/2} = \frac{7.6}{2} = 3.8$  days

- (d) The alpha-particles become helium atoms which are collected in the vacuum shown in Fig. 10.1.

Explain, in terms of the properties of alpha-particles, why the wall of the inner glass tube must be extremely thin.

The penetrating power of alpha particles is very less [1]

- (e) In some parts of the world, radon-222 accumulates in the air in buildings and is breathed in by people.

Explain why the presence of an alpha-emitter in the lungs is particularly hazardous.

alpha particle is strongly ionising which causes cell mutation or cancers [2]

[Total: 15]

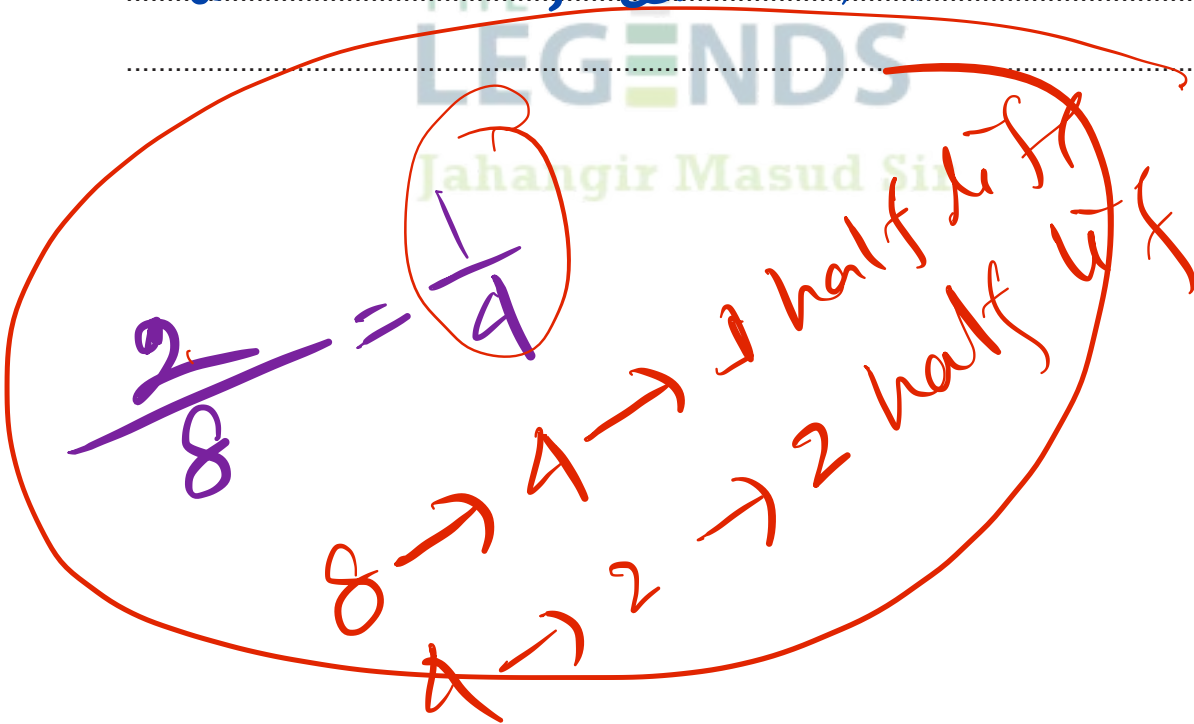

- 4 On which car is there a resultant force?
- A** a car moving along a straight horizontal road at constant speed
- B** a car moving around a bend at constant speed
- C** a car moving uphill at constant velocity
- D** a car that is stationary
- 5 Which piece of apparatus may be used to compare the masses of two objects?
- A** balance
- B** manometer
- C** measuring cylinder
- D** micrometer
- 6 The graph shows how the extension of a spring changes with the masses suspended from it when the spring is on planet X and when the spring is on planet Y.

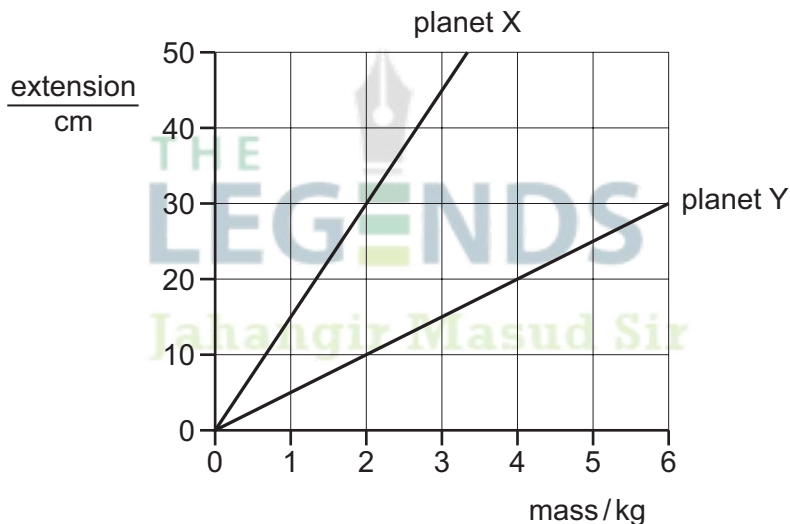

Which conclusion can be drawn from these graphs?

- A** It is not possible to compare the gravitational field strengths on planets X and Y.
- B** The gravitational field strength on planet X is equal to the gravitational field strength on planet Y.
- C** The gravitational field strength on planet X is one third of the gravitational field strength on planet Y.
- D** The gravitational field strength on planet X is three times the gravitational field strength on planet Y.